

STANDARD PRODUCT GUIDE 2017





THE dti™ FAMILY

30 years ago, dti™ discovered that the waterjet orifice is often the most overlooked component in a waterjet cutting system, and yet without it, the entire system would fail to function. For this reason, dti™ set lofty goals to transform the industry with our “cutting edge” orifice solutions. Today, dti™ is the leading waterjet orifice and cutting head provider in the industry. Our goal is to provide dependable, precision products that significantly cut production costs for our customers and support the continued growth of the entire waterjet industry. dti™ takes great pride knowing our products consistently outperform competitors and provide sustainable industry solutions.



THE DIAMOND INSIDE

AMAZING PERFORMANCE STARTS WITH dti™ INSIDE

A better waterjet system starts with the best orifice. Be it ruby, sapphire, dtiCORE™ Diamond or tetraCORE™, a dti™ waterjet orifice is engineered and tested to deliver optimum performance every time. This dedication to perfection has made dti™ waterjet orifices the OEM choice inside top waterjet brands.

THE POWER TO PRODUCE MORE

With 30 years' experience, dti™ has gained a worldwide reputation for a perfect marriage of technology, innovation and service. In abrasive and water only cutting, our focus continues to be the development of waterjet orifice solutions that provide reliable, efficient, user friendly technology, yielding superior quality and increased productivity. The only thing more amazing than dti™ orifice technology, is what you'll do with it.



THE dtiCORE™ DIFFERENCE

STRENGTH

Each dtiCORE™ Diamond is oriented to utilize its strongest and most resistant surface. It is cut in a unique way to ensure strength through the elimination of stress points that lead to premature failure at areas of increased localized stress. We use only the finest materials and designs to best support the diamond and ensure maximum mount life.

EXPERT DESIGN

Our design utilizes an internal bearing held to exact tolerances to accurately control flow rates and create tighter jet stream coherency. Another key design element is the incorporation of an inlet flare that evenly distributes force over the area of the jewel to increase fatigue strength and provide consistent cutting parameters. dtiCORE™ Diamonds employ proprietary alignment procedures for optimized jet stream accuracy and extended life to the surrounding equipment.

VERSATILITY

The shape of the dtiCORE™ Diamond allows mounting in all typical orifice assemblies. Our diamonds are manufactured in a large range of sizes to provide high tolerance cutting in virtually every cutting or spraying application.

QUALITY STANDARDS

The dtiCORE™ Diamond is a precision orifice held to the highest tolerances in the industry. Each diamond is individually tested under high pressure before ever leaving the lab, to ensure unsurpassed jet stream quality and alignment in every orifice.



INDEX

dtiCORE™ Diamond Orifices.....	1-11
Diamond Guard Filters	12
tetraCORE™ Orifices	13-23
Ruby & Sapphire Orifices	24-38
SLICE2	39
SLICE2 Accessories	40

DIAMOND ORIFICES

DTI-05

SIMILAR TO THE FOLLOWING
STANDARD
COMADUR TYPE 18

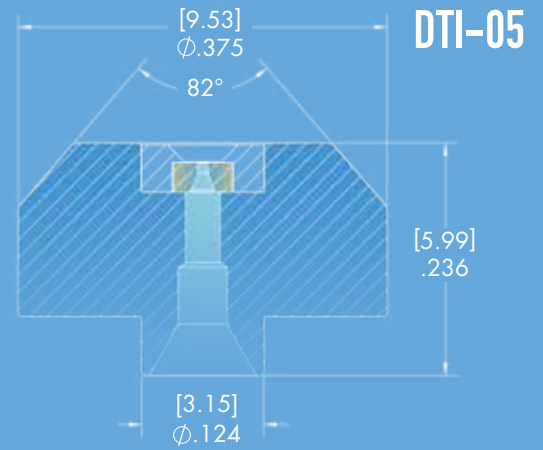

Front view



Enlarged view

PART NUMBERS & STANDARD SIZES

DTI PART #	inch	mm
DA-05W-04	.004	0,10
DA-05W-05	.005	0,13
DA-05W-06	.006	0,15
DA-05W-07	.007	0,18
DA-05W-08	.008	0,20
DA-05W-09	.009	0,23
DA-05-10	.010	0,25
DA-05-11	.011	0,28
DA-05-12	.012	0,30
DA-05-13	.013	0,33
DA-05-14	.014	0,35
DA-05-15	.015	0,38
DA-05-16	.016	0,40
DA-05-17	.017	0,43
DA-05-18	.018	0,45

Orifice retained with aerospace grade titanium for maximum strength and reliability. Additional orifice sizes and mount specifications available upon request.

PROTECT YOUR INVESTMENT

To prevent orifice plugging and increase the lifetime of your dtiCORE™ Diamond, use a dti™ Diamond Guard Filter. For more information see page 12.



DIAMOND TECHNOLOGY INNOVATIONS

DIAMOND ORIFICES

DTI-06

SIMILAR TO THE FOLLOWING

PL-2

COMADUR TYPE 30

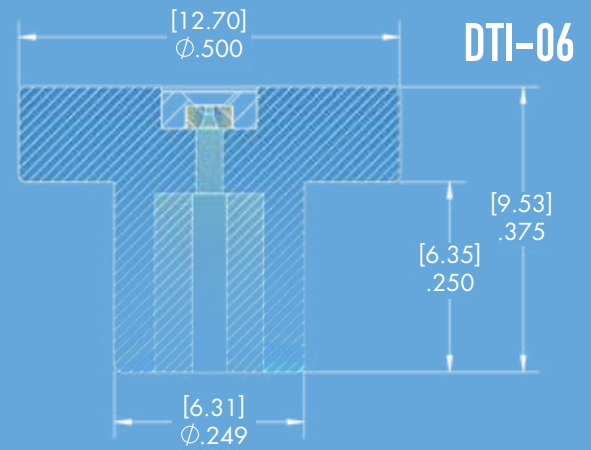

Front view



Enlarged view

PART NUMBERS & STANDARD SIZES

DTI PART #	inch	mm
DA-06-04	.004	0,10
DA-06-05	.005	0,13
DA-06-06	.006	0,15
DA-06-07	.007	0,18
DA-06-08	.008	0,20
DA-06-09	.009	0,23
DA-06-10	.010	0,25
DA-06-11	.011	0,28
DA-06-12	.012	0,30
DA-06-13	.013	0,33
DA-06-14	.014	0,35
DA-06-15	.015	0,38
DA-06-16	.016	0,40
DA-06-17	.017	0,43
DA-06-18	.018	0,45

Orifice retained with aerospace grade titanium for maximum strength and reliability. Additional orifice sizes and mount specifications available upon request.

PROTECT YOUR INVESTMENT

To prevent orifice plugging and increase the lifetime of your dtiCORE™ Diamond, use a dti™ Diamond Guard Filter. For more information see page 12.



DIAMOND TECHNOLOGY INNOVATIONS

DIAMOND ORIFICES

DTI-14

SIMILAR TO THE FOLLOWING

P - V

COMADUR TYPE 26

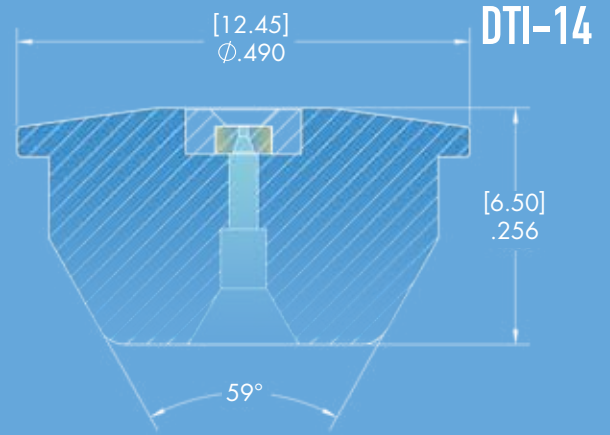

Front view



Enlarged view

PART NUMBERS & STANDARD SIZES

DTI PART #	inch	mm
DA-14-04	.004	0,10
DA-14-05	.005	0,13
DA-14-06	.006	0,15
DA-14-07	.007	0,18
DA-14-08	.008	0,20
DA-14-09	.009	0,23
DA-14-10	.010	0,25
DA-14-11	.011	0,28
DA-14-12	.012	0,30
DA-14-13	.013	0,33
DA-14-14	.014	0,35
DA-14-15	.015	0,38
DA-14-16	.016	0,40
DA-14-17	.017	0,43
DA-14-18	.018	0,45

Orifice retained with aerospace grade titanium for maximum strength and reliability. Additional orifice sizes and mount specifications available upon request.

PROTECT YOUR INVESTMENT

To prevent orifice plugging and increase the lifetime of your dtiCORE™ Diamond, use a dti™ Diamond Guard Filter. For more information see page 12.



DIAMOND TECHNOLOGY INNOVATIONS

DIAMOND ORIFICES

DTI-16

SIMILAR TO THE FOLLOWING

P-III

COMADUR TYPE 23

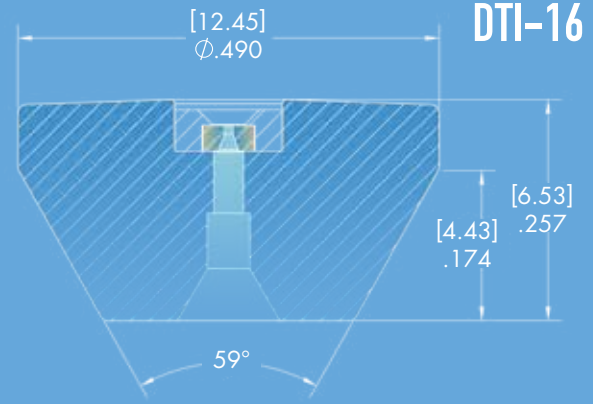

Front view



Enlarged view

PART NUMBERS & STANDARD SIZES

DTI PART #	inch	mm
DA-16-04	.004	0,10
DA-16-05	.005	0,13
DA-16-06	.006	0,15
DA-16-07	.007	0,18
DA-16-08	.008	0,20
DA-16-09	.009	0,23
DA-16-10	.010	0,25
DA-16-11	.011	0,28
DA-16-12	.012	0,30
DA-16-13	.013	0,33
DA-16-14	.014	0,35
DA-16-15	.015	0,38
DA-16-16	.016	0,40
DA-16-17	.017	0,43
DA-16-18	.018	0,45

Orifice retained with aerospace grade titanium for maximum strength and reliability. Additional orifice sizes and mount specifications available upon request.

PROTECT YOUR INVESTMENT

To prevent orifice plugging and increase the lifetime of your dtiCORE™ Diamond, use a dti™ Diamond Guard Filter. For more information see page 12.



DIAMOND TECHNOLOGY INNOVATIONS

DIAMOND ORIFICES

DTI-20

SIMILAR TO THE FOLLOWING
P-IV

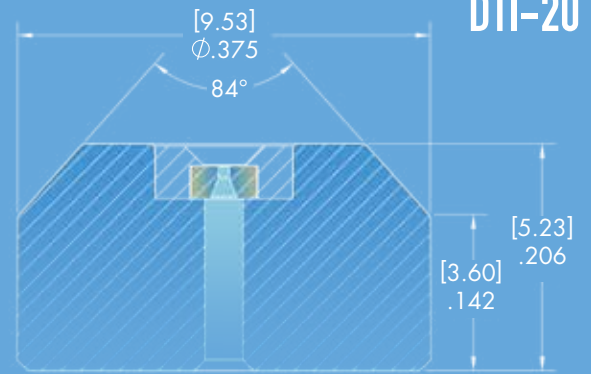

Front view

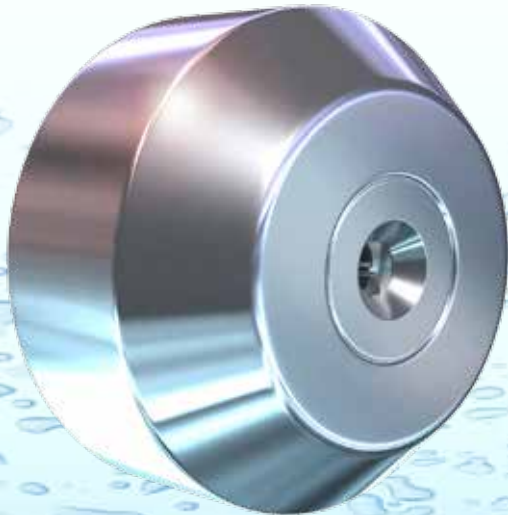

Enlarged view

PART NUMBERS & STANDARD SIZES

DTI PART #	inch	mm
DA-20-04	.004	0,10
DA-20-05	.005	0,13
DA-20-06	.006	0,15
DA-20-07	.007	0,18
DA-20-08	.008	0,20
DA-20-09	.009	0,23
DA-20-10	.010	0,25
DA-20-11	.011	0,28
DA-20-12	.012	0,30
DA-20-13	.013	0,33
DA-20-14	.014	0,35
DA-20-15	.015	0,38
DA-20-16	.016	0,40
DA-20-17	.017	0,43
DA-20-18	.018	0,45

Orifice retained with aerospace grade titanium for maximum strength and reliability. Additional orifice sizes and mount specifications available upon request.

PROTECT YOUR INVESTMENT

To prevent orifice plugging and increase the lifetime of your dtiCORE™ Diamond, use a dti™ Diamond Guard Filter. For more information see page 12.



DIAMOND TECHNOLOGY INNOVATIONS

DIAMOND ORIFICES

DTI-28

SIMILAR TO THE FOLLOWING
COMADUR TYPE 27

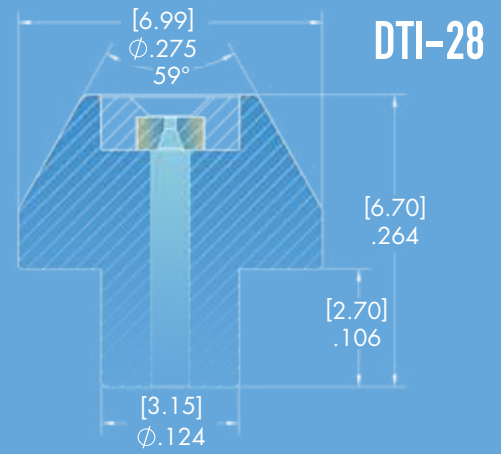

Front view

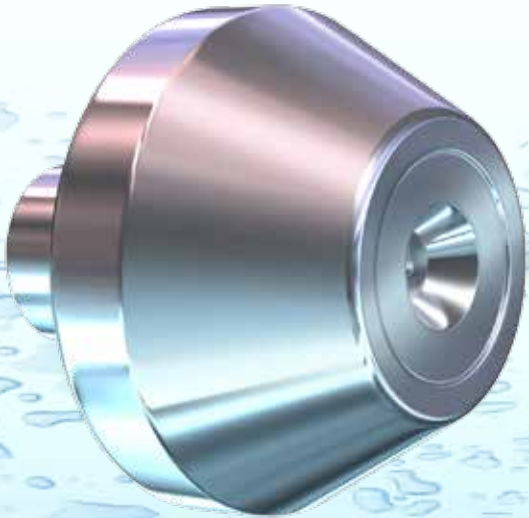

Enlarged view

PART NUMBERS & STANDARD SIZES

DTI PART #	inch	mm
DA-28W-04	.004	0,10
DA-28W-05	.005	0,13
DA-28W-06	.006	0,15
DA-28W-07	.007	0,18
DA-28W-08	.008	0,20
DA-28W-09	.009	0,23
DA-28-10	.010	0,25
DA-28-11	.011	0,28
DA-28-12	.012	0,30
DA-28-13	.013	0,33
DA-28-14	.014	0,35
DA-28-15	.015	0,38
DA-28-16	.016	0,40
DA-28-17	.017	0,43
DA-28-18	.018	0,45

Orifice retained with aerospace grade titanium for maximum strength and reliability. Additional orifice sizes and mount specifications available upon request.

PROTECT YOUR INVESTMENT

To prevent orifice plugging and increase the lifetime of your dtiCORE™ Diamond, use a dti™ Diamond Guard Filter. For more information see page 12.



DIAMOND TECHNOLOGY INNOVATIONS

DIAMOND ORIFICES

DTI-30

SIMILAR TO THE FOLLOWING
COMADUR TYPE 25

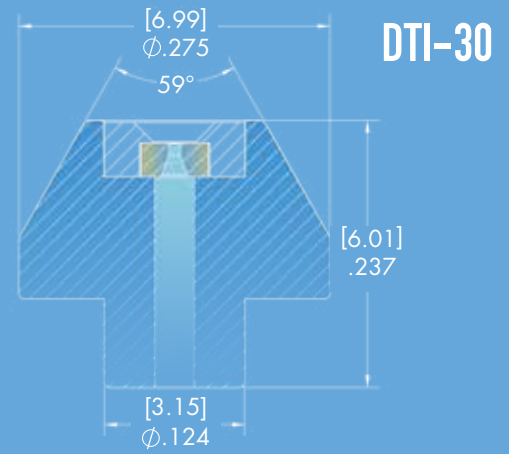

Front view

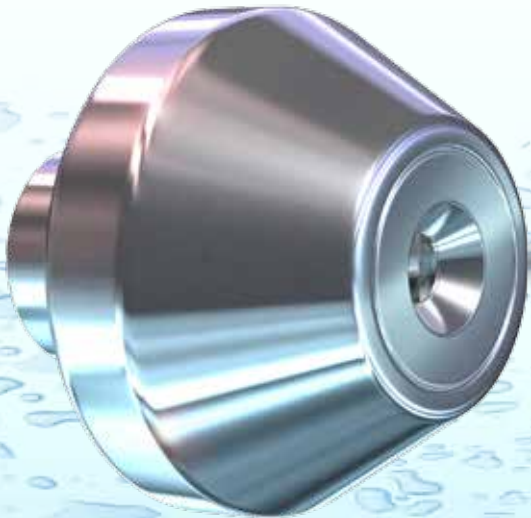

Enlarged view

PART NUMBERS & STANDARD SIZES

DTI PART #	inch	mm
DA-30W-04	.004	0,10
DA-30W-05	.005	0,13
DA-30W-06	.006	0,15
DA-30W-07	.007	0,18
DA-30W-08	.008	0,20
DA-30W-09	.009	0,23
DA-30-10	.010	0,25
DA-30-11	.011	0,28
DA-30-12	.012	0,30
DA-30-13	.013	0,33
DA-30-14	.014	0,35
DA-30-15	.015	0,38
DA-30-16	.016	0,40
DA-30-17	.017	0,43
DA-30-18	.018	0,45

Orifice retained with aerospace grade titanium for maximum strength and reliability. Additional orifice sizes and mount specifications available upon request.

PROTECT YOUR INVESTMENT

To prevent orifice plugging and increase the lifetime of your dtiCORE™ Diamond, use a dti™ Diamond Guard Filter. For more information see page 12.



DIAMOND TECHNOLOGY INNOVATIONS

DIAMOND ORIFICES

DTI-57

SIMILAR TO THE FOLLOWING
LOW MASS

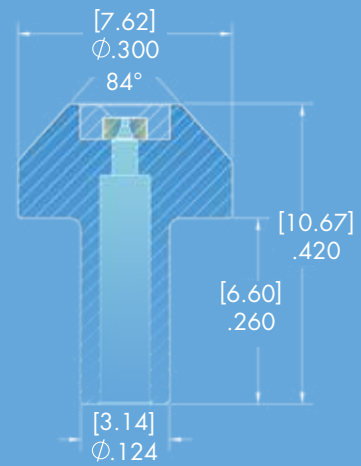

DTI-57



Front view

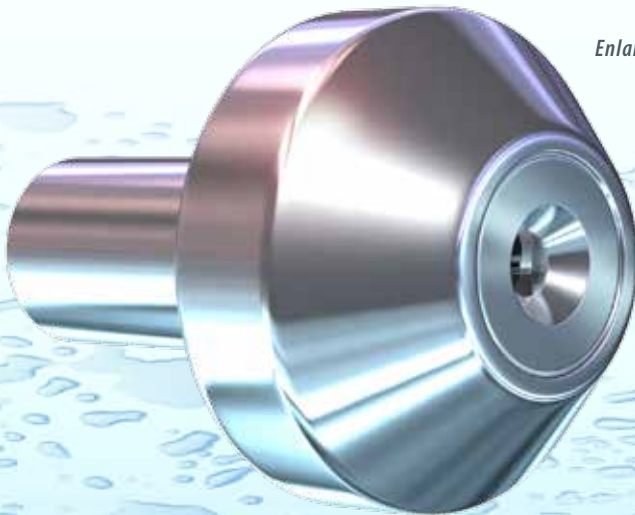

Enlarged view

PART NUMBERS & STANDARD SIZES

DTI PART #	inch	mm
DA-57W-04	.004	0,10
DA-57W-05	.005	0,13
DA-57W-06	.006	0,15
DA-57W-07	.007	0,18
DA-57W-08	.008	0,20
DA-57W-09	.009	0,23
DA-57W-10	.010	0,25
DA-57W-11	.011	0,28
DA-57W-12	.012	0,30
DA-57W-13	.013	0,33
DA-57W-14	.014	0,35
DA-57W-15	.015	0,38
DA-57W-16	.016	0,40
DA-57W-17	.017	0,43
DA-57W-18	.018	0,45

Orifice retained with aerospace grade titanium for maximum strength and reliability. Additional orifice sizes and mount specifications available upon request.

PROTECT YOUR INVESTMENT

To prevent orifice plugging and increase the lifetime of your dtiCORE™ Diamond, use a dti™ Diamond Guard Filter. For more information see page 12.



DIAMOND TECHNOLOGY INNOVATIONS

DIAMOND ORIFICES

DTI-58

SIMILAR TO THE FOLLOWING
LONG STEM
COMADUR TYPE 10

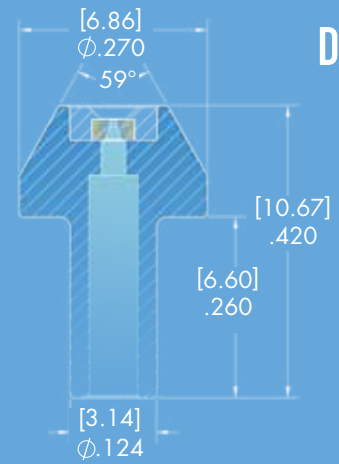

DTI-58



Front view



Enlarged view

PART NUMBERS & STANDARD SIZES

DTI PART #	inch	mm
DA-58W-04	.004	0,10
DA-58W-05	.005	0,13
DA-58W-06	.006	0,15
DA-58W-07	.007	0,18
DA-58W-08	.008	0,20
DA-58W-09	.009	0,23
DA-58W-10	.010	0,25
DA-58W-11	.011	0,28
DA-58W-12	.012	0,30
DA-58W-13	.013	0,33
DA-58W-14	.014	0,35
DA-58W-15	.015	0,38
DA-58W-16	.016	0,40
DA-58W-17	.017	0,43
DA-58W-18	.018	0,45

Orifice retained with aerospace grade titanium for maximum strength and reliability. Additional orifice sizes and mount specifications available upon request.

PROTECT YOUR INVESTMENT

To prevent orifice plugging and increase the lifetime of your dtiCORE™ Diamond, use a dti™ Diamond Guard Filter. For more information see page 12.



DIAMOND TECHNOLOGY INNOVATIONS

DIAMOND ORIFICES

DTI-62

SIMILAR TO THE FOLLOWING
P-II STEP
COMADUR TYPE 14

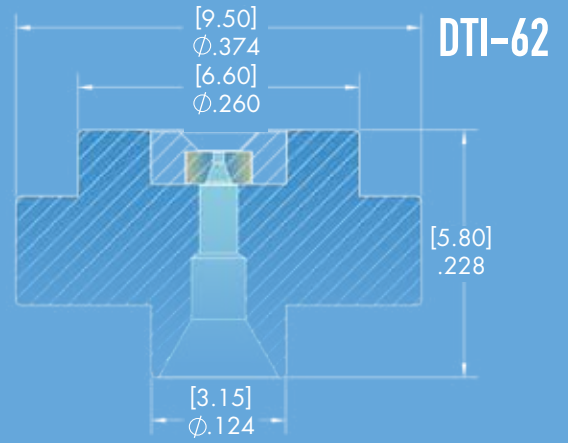

Front view

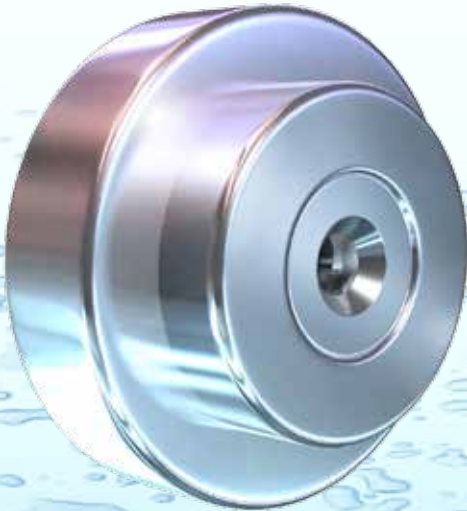

Enlarged view

PART NUMBERS & STANDARD SIZES

DTI PART #	inch	mm
DA-62W-04	.004	0,10
DA-62W-05	.005	0,13
DA-62W-06	.006	0,15
DA-62W-07	.007	0,18
DA-62W-08	.008	0,20
DA-62W-09	.009	0,23
DA-62W-10	.010	0,25
DA-62W-11	.011	0,28
DA-62W-12	.012	0,30
DA-62W-13	.013	0,33
DA-62W-14	.014	0,35
DA-62W-15	.015	0,38
DA-62W-16	.016	0,40
DA-62W-17	.017	0,43
DA-62W-18	.018	0,45

Orifice retained with aerospace grade titanium for maximum strength and reliability. Additional orifice sizes and mount specifications available upon request.

PROTECT YOUR INVESTMENT

To prevent orifice plugging and increase the lifetime of your dtiCORE™ Diamond, use a dti™ Diamond Guard Filter. For more information see page 12.



DIAMOND TECHNOLOGY INNOVATIONS

DIAMOND ORIFICES

DTI-65

SIMILAR TO THE FOLLOWING
LOW MASS
COMADUR TYPE 20

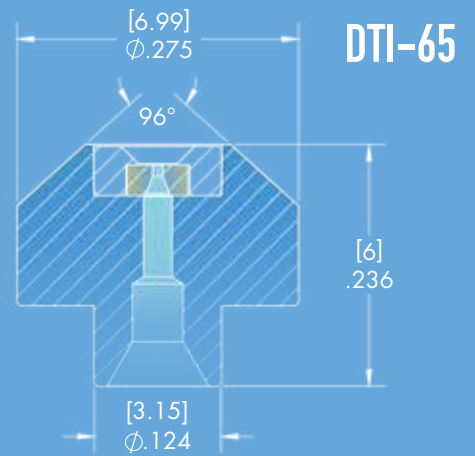

Front view

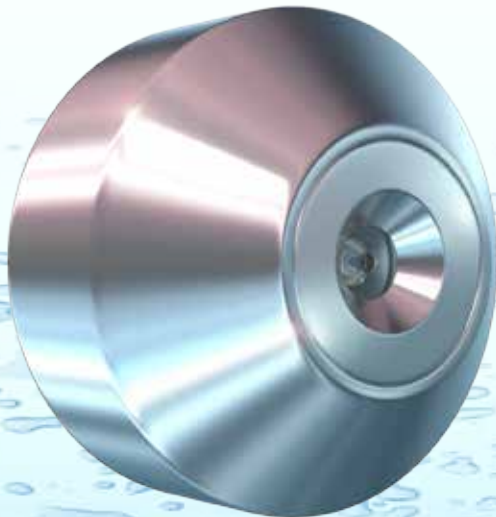

Enlarged view

PART NUMBERS & STANDARD SIZES

DTI PART #	inch	mm
DA-65W-04	.004	0,10
DA-65W-05	.005	0,13
DA-65W-06	.006	0,15
DA-65W-07	.007	0,18
DA-65W-08	.008	0,20
DA-65W-09	.009	0,23
DA-65W-10	.010	0,25
DA-65W-11	.011	0,28
DA-65W-12	.012	0,30
DA-65W-13	.013	0,33
DA-65W-14	.014	0,35
DA-65W-15	.015	0,38
DA-65W-16	.016	0,40
DA-65W-17	.017	0,43
DA-65W-18	.018	0,45

Orifice retained with aerospace grade titanium for maximum strength and reliability. Additional orifice sizes and mount specifications available upon request.

PROTECT YOUR INVESTMENT

To prevent orifice plugging and increase the lifetime of your dtiCORE™ Diamond, use a dti™ Diamond Guard Filter. For more information see page 12.



DIAMOND TECHNOLOGY INNOVATIONS

DTI SOLUTIONS

THE dti™ DIAMOND GUARD FILTER

THE PROBLEM

- Plugged or Chipped Orifices
- Premature Wear of Cutting Head Components
- Reduced Jet Stream Coherency
- Inefficient Cutting

Within the internal components of every waterjet system, errant particles become dislodged and travel through the high pressure lines. These particles end up at the waterjet orifice, impacting and potentially damaging the orifice edge. When debris is larger than the hole in the orifice, the orifice assembly becomes plugged or partially blocked.

THE SOLUTION

The dti™ Diamond Guard Filter is designed to simply and effectively capture debris larger than .0055" (0,14mm) from impacting or blocking the orifice. Any particles small enough to pass through the DG Filter will also exit safely through the hole of the waterjet orifice.

DG Filters and Adapters allow for ease of installation in any waterjet system's 1/4" or 3/8" high pressure lines. The DG Filter is installed as close to the waterjet orifice assembly as possible, with the most common location being in the HP fitting at the on/off valve assembly.

When paired with any dti™ orifice assembly, the dti™ Diamond Guard Filter ensures precision cutting throughout every job.



To Request A Quote:

Contact your waterjet parts supplier or contact us for your nearest authorized distributor: info@dtiINSIDE.com

DIAMOND GUARD FILTERS

◆ PROTECT YOUR INVESTMENT



M-FIL-01
3/8" Diamond Guard Filter
M-ADP-06
3/8" Diamond Guard Insert



MA-FIL-07
1/4"F to 3/8"M Diamond Guard Filter Assembly
MA-FIL-07NF
1/4"F to 3/8"M DGF Body & Insert (No Filter)



MA-FIL-03
3/8" Diamond Guard Filter & Insert Combo



MA-FIL-08
1/4"F to 1/4"M 90K PSI Diamond Guard Filter Assembly
MA-FIL-08NF
1/4"F to 1/4"M 90K PSI DGF Body & Insert (No Filter)



MA-FIL-02
3/8"F to 3/8"M Diamond Guard Filter Assembly
MA-FIL-02NF
3/8"F to 3/8"M DGF Body (No Filter)



MA-FIL-09
M16 F to M16 M Diamond Guard Filter METRIC M16-1.5 Threads
MA-FIL-09NF
M16 F to M16 M DGF Body & Insert (No Filter) METRIC M16-1.5 Threads



MA-FIL-06
1/4"F to 1/4"M Diamond Guard Filter Assembly
MA-FIL-06NF
1/4"F to 1/4"M DGF Body & Insert (No Filter)



M-HOU-02
3/8"F to 3/8"F Diamond Guard Filter Inline Housing



INTRODUCING tetraCORE™

Introducing tetraCORE™, the material of the future for waterjet cutting and cleaning applications. A breakthrough in material science, tetraCORE™ is the first new grade of orifice material introduced into the waterjet industry in over 30 years. An elaborate technology engineered at the atomic level, tetraCORE™ is the achievement of a strategic structuring of the atomic lattice and has been designed to employ an extremely tough and durable tetrahedral bond that will resist erosion, chipping and fracturing, while reducing operating costs.

PERFORMANCE ADVANTAGES

- 10X Longer life
- Binderless structure eliminates chemical reaction to water and subsequent premature edge erosion
- Greater jet stream consistency
- Reduced operating costs
- Excellent reliability in harsh AWJ environments
- Less supervision required

RETAIL PRICE STRUCTURE

QUANTITY	PRICE EACH
1-4	\$249
5-9	\$199
10 or more	\$149

NEW MATERIAL GRADE

Precision engineered to offer predictable performance, tetraCORE™ waterjet orifices make waterjets a viable option for almost any cutting application. Manufactured under tightly controlled conditions, tetraCORE™ approaches the hardness and wear resistance of diamond, while offering prices comparable to ruby and sapphire. Extensive testing of tetraCORE™'s durability consistently delivered 400 or more cut hours, a full ten times longer than ruby & sapphire orifices could deliver.

Waterjets that are upgraded with a tetraCORE™ orifice provide operators with:

- ◆ LONGER CUTTING HOURS
- ◆ MINIMIZED MATERIAL WASTE
- ◆ INCREASED EQUIPMENT ROI
- ◆ OPERATIONAL EXCELLENCE

WATERJET ORIFICE PERFORMANCE

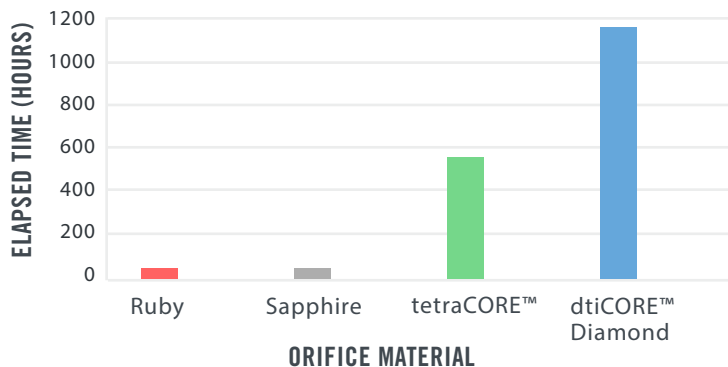

TETRACORE ORIFICES

DTI-05

SIMILAR TO THE FOLLOWING
STANDARD
COMADUR TYPE 18

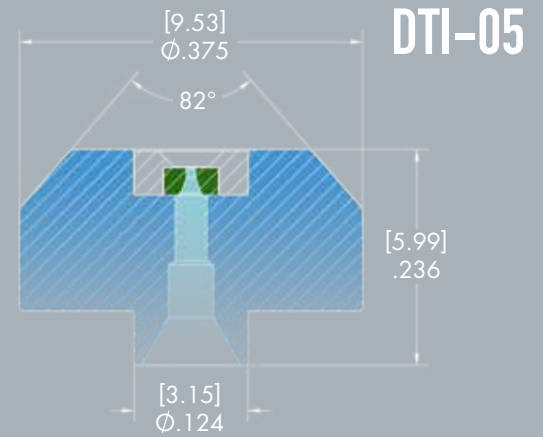

Front view



Enlarged view

PART NUMBERS & STANDARD SIZES

DTI PART #	inch	mm
TA-05-04	.004	0,10
TA-05-05	.005	0,13
TA-05-06	.006	0,15
TA-05-07	.007	0,18
TA-05-08	.008	0,20
TA-05-09	.009	0,23
TA-05-10	.010	0,25
TA-05-11	.011	0,28
TA-05-12	.012	0,30
TA-05-13	.013	0,33
TA-05-14	.014	0,35
TA-05-15	.015	0,38
TA-05-16	.016	0,40
TA-05-17	.017	0,43
TA-05-18	.018	0,45

Orifice retained with aerospace grade titanium for maximum strength and reliability. Additional orifice sizes and mount specifications available upon request.



TETRACORE ORIFICES

DTI-06

SIMILAR TO THE FOLLOWING
 PL-2
 COMADUR TYPE 30

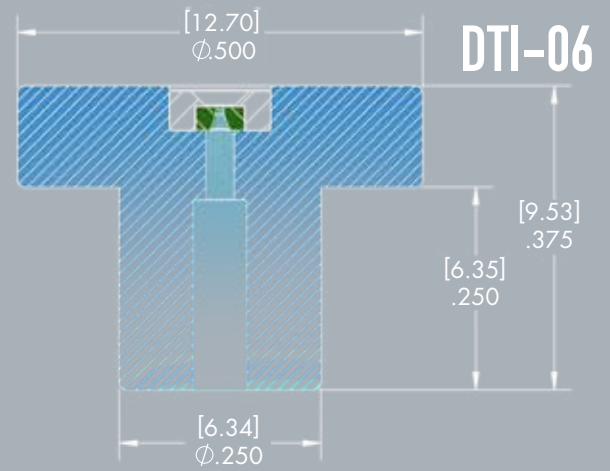

Front view

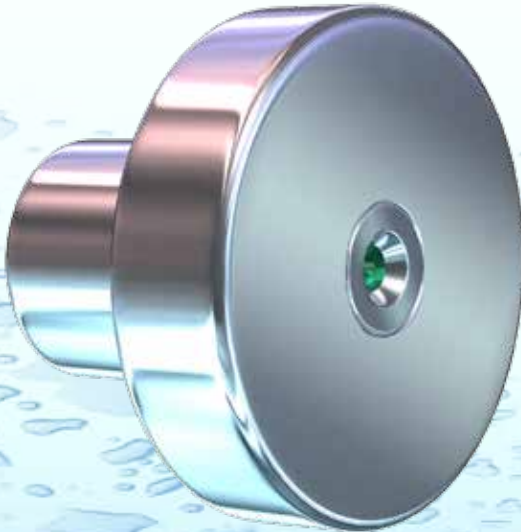

Enlarged view

PART NUMBERS & STANDARD SIZES

DTI PART #	inch	mm
TA-06-04	.004	0,10
TA-06-05	.005	0,13
TA-06-06	.006	0,15
TA-06-07	.007	0,18
TA-06-08	.008	0,20
TA-06-09	.009	0,23
TA-06-10	.010	0,25
TA-06-11	.011	0,28
TA-06-12	.012	0,30
TA-06-13	.013	0,33
TA-06-14	.014	0,35
TA-06-15	.015	0,38
TA-06-16	.016	0,40
TA-06-17	.017	0,43
TA-06-18	.018	0,45

Orifice retained with aerospace grade titanium for maximum strength and reliability. Additional orifice sizes and mount specifications available upon request.



TETRACORE ORIFICES

DTI-14

SIMILAR TO THE FOLLOWING

P-V

COMADUR TYPE 26

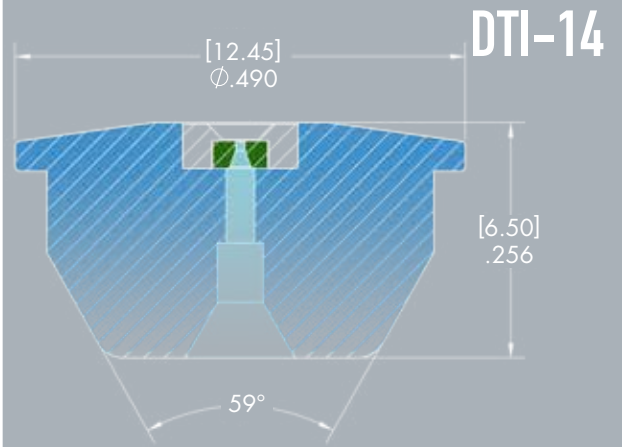

Front view



Enlarged view

PART NUMBERS & STANDARD SIZES

DTI PART #	inch	mm
TA-14-04	.004	0,10
TA-14-05	.005	0,13
TA-14-06	.006	0,15
TA-14-07	.007	0,18
TA-14-08	.008	0,20
TA-14-09	.009	0,23
TA-14-10	.010	0,25
TA-14-11	.011	0,28
TA-14-12	.012	0,30
TA-14-13	.013	0,33
TA-14-14	.014	0,35
TA-14-15	.015	0,38
TA-14-16	.016	0,40
TA-14-17	.017	0,43
TA-14-18	.018	0,45

Orifice retained with aerospace grade titanium for maximum strength and reliability. Additional orifice sizes and mount specifications available upon request.



TETRACORE ORIFICES

DTI-16

SIMILAR TO THE FOLLOWING
P-III
COMADUR TYPE 23

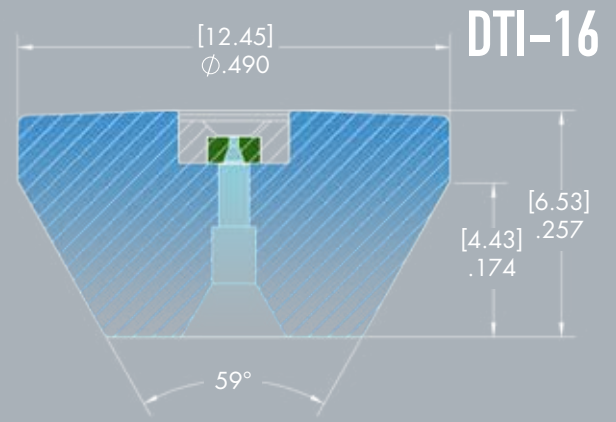

Front view

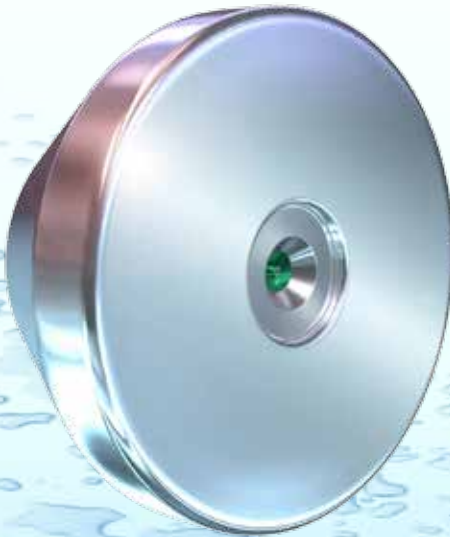

Enlarged view

PART NUMBERS & STANDARD SIZES

DTI PART #	inch	mm
TA-16-04	.004	0,10
TA-16-05	.005	0,13
TA-16-06	.006	0,15
TA-16-07	.007	0,18
TA-16-08	.008	0,20
TA-16-09	.009	0,23
TA-16-10	.010	0,25
TA-16-11	.011	0,28
TA-16-12	.012	0,30
TA-16-13	.013	0,33
TA-16-14	.014	0,35
TA-16-15	.015	0,38
TA-16-16	.016	0,40
TA-16-17	.017	0,43
TA-16-18	.018	0,45

Orifice retained with aerospace grade titanium for maximum strength and reliability. Additional orifice sizes and mount specifications available upon request.



TETRACORE ORIFICES

DTI-20

SIMILAR TO THE FOLLOWING
P-IV

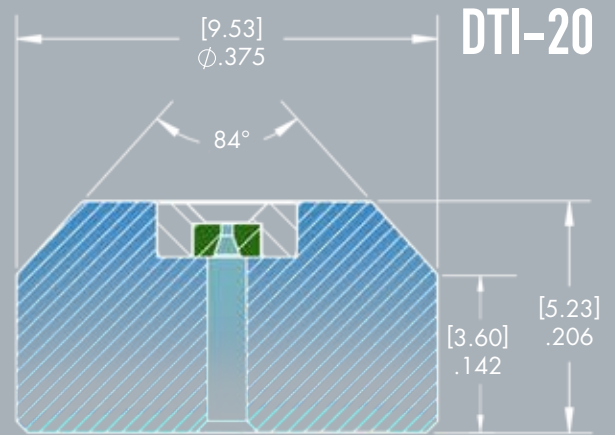

Front view

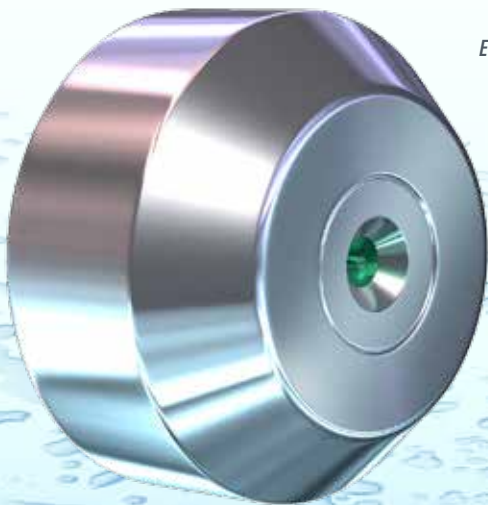

Enlarged view

PART NUMBERS & STANDARD SIZES

DTI PART #	inch	mm
TA-20-04	.004	0,10
TA-20-05	.005	0,13
TA-20-06	.006	0,15
TA-20-07	.007	0,18
TA-20-08	.008	0,20
TA-20-09	.009	0,23
TA-20-10	.010	0,25
TA-20-11	.011	0,28
TA-20-12	.012	0,30
TA-20-13	.013	0,33
TA-20-14	.014	0,35
TA-20-15	.015	0,38
TA-20-16	.016	0,40
TA-20-17	.017	0,43
TA-20-18	.018	0,45

Orifice retained with aerospace grade titanium for maximum strength and reliability. Additional orifice sizes and mount specifications available upon request.



TETRACORE ORIFICES

DTI-28

SIMILAR TO THE FOLLOWING
COMADUR TYPE 27

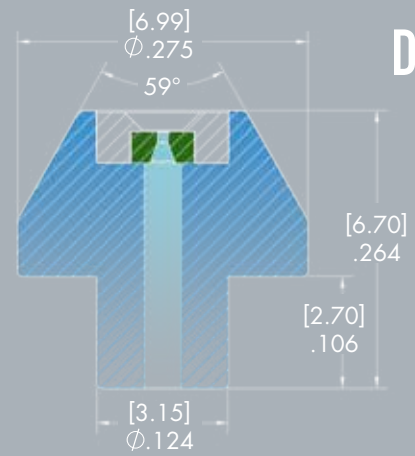

DTI-28



Front view

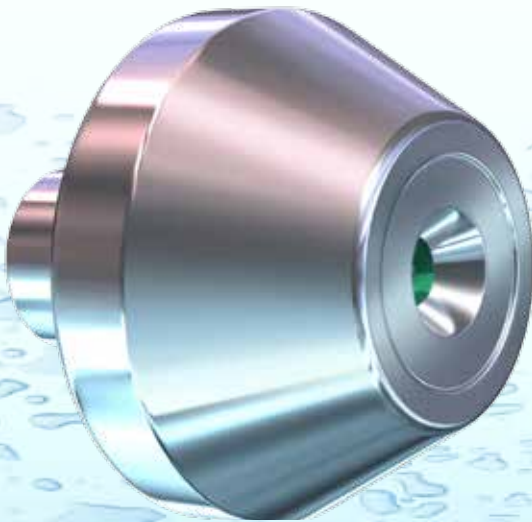

Enlarged view

PART NUMBERS & STANDARD SIZES

DTI PART #	inch	mm
TA-28-04	.004	0,10
TA-28-05	.005	0,13
TA-28-06	.006	0,15
TA-28-07	.007	0,18
TA-28-08	.008	0,20
TA-28-09	.009	0,23
TA-28-10	.010	0,25
TA-28-11	.011	0,28
TA-28-12	.012	0,30
TA-28-13	.013	0,33
TA-28-14	.014	0,35
TA-28-15	.015	0,38
TA-28-16	.016	0,40
TA-28-17	.017	0,43
TA-28-18	.018	0,45

Orifice retained with aerospace grade titanium for maximum strength and reliability. Additional orifice sizes and mount specifications available upon request.



TETRACORE ORIFICES

DTI-30

SIMILAR TO THE FOLLOWING
COMADUR TYPE 25

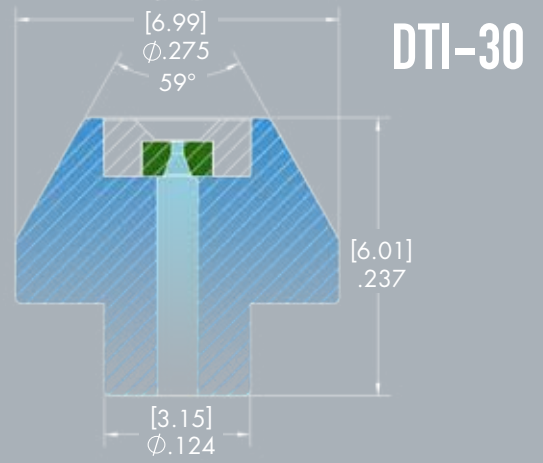

Front view

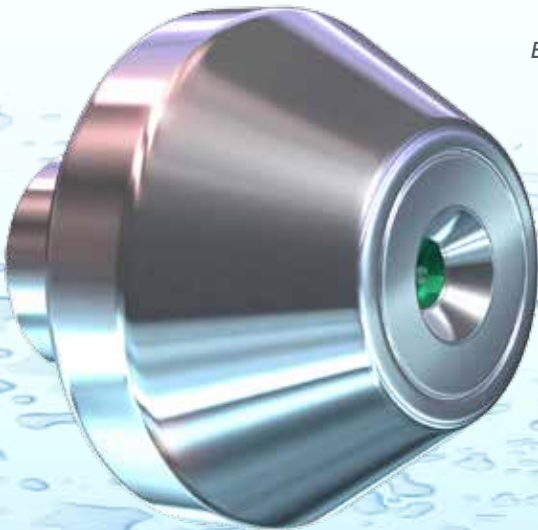

Enlarged view

PART NUMBERS & STANDARD SIZES

DTI PART #	inch	mm
TA-30-04	.004	0,10
TA-30-05	.005	0,13
TA-30-06	.006	0,15
TA-30-07	.007	0,18
TA-30-08	.008	0,20
TA-30-09	.009	0,23
TA-30-10	.010	0,25
TA-30-11	.011	0,28
TA-30-12	.012	0,30
TA-30-13	.013	0,33
TA-30-14	.014	0,35
TA-30-15	.015	0,38
TA-30-16	.016	0,40
TA-30-17	.017	0,43
TA-30-18	.018	0,45

Orifice retained with aerospace grade titanium for maximum strength and reliability. Additional orifice sizes and mount specifications available upon request.



TETRACORE ORIFICES

DTI-58

SIMILAR TO THE FOLLOWING
LONG STEM
COMADUR TYPE 10

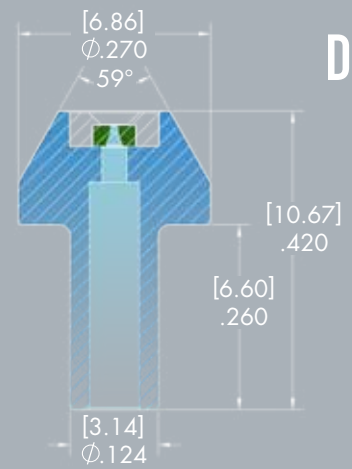

DTI-58



Front view

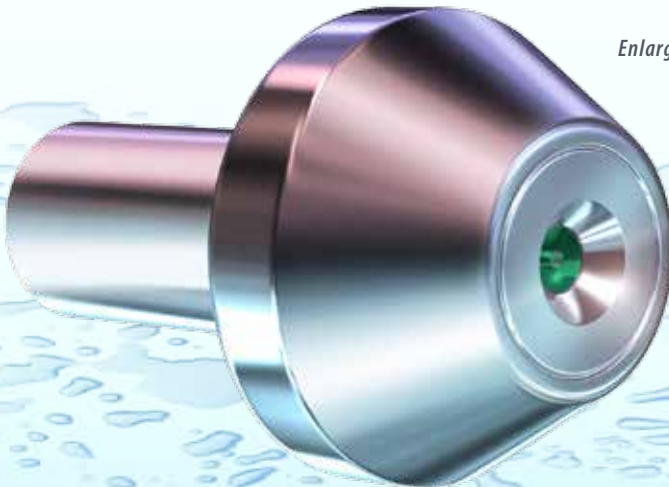

Enlarged view

PART NUMBERS & STANDARD SIZES

DTI PART #	inch	mm
TA-58-04	.004	0,10
TA-58-05	.005	0,13
TA-58-06	.006	0,15
TA-58-07	.007	0,18
TA-58-08	.008	0,20
TA-58-09	.009	0,23
TA-58-10	.010	0,25
TA-58-11	.011	0,28
TA-58-12	.012	0,30
TA-58-13	.013	0,33
TA-58-14	.014	0,35
TA-58-15	.015	0,38
TA-58-16	.016	0,40
TA-58-17	.017	0,43
TA-58-18	.018	0,45

Orifice retained with aerospace grade titanium for maximum strength and reliability. Additional orifice sizes and mount specifications available upon request.



TETRACORE ORIFICES

DTI-62

SIMILAR TO THE FOLLOWING
P-II STEP
COMADUR TYPE 14

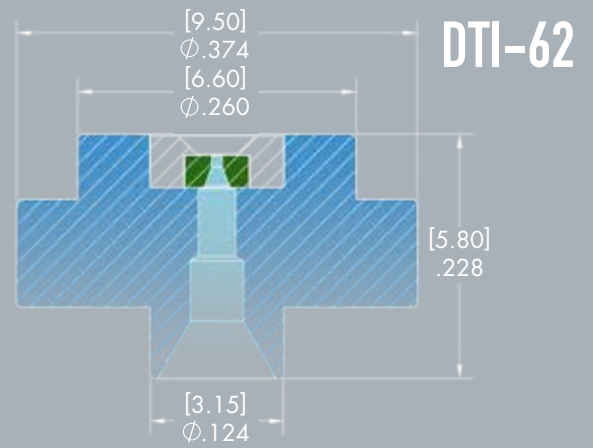

Front view

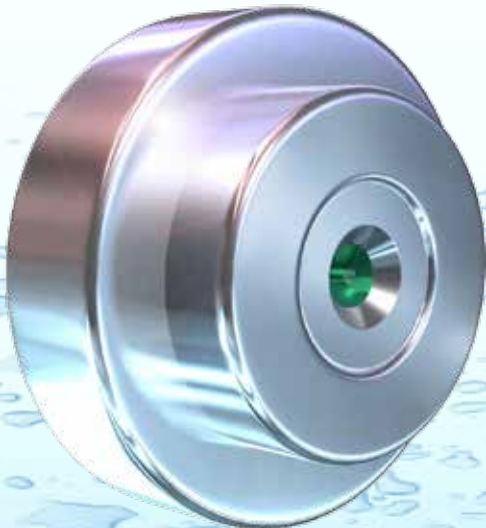

Enlarged view

PART NUMBERS & STANDARD SIZES

DTI PART #	inch	mm
TA-62-04	.004	0,10
TA-62-05	.005	0,13
TA-62-06	.006	0,15
TA-62-07	.007	0,18
TA-62-08	.008	0,20
TA-62-09	.009	0,23
TA-62-10	.010	0,25
TA-62-11	.011	0,28
TA-62-12	.012	0,30
TA-62-13	.013	0,33
TA-62-14	.014	0,35
TA-62-15	.015	0,38
TA-62-16	.016	0,40
TA-62-17	.017	0,43
TA-62-18	.018	0,45

Orifice retained with aerospace grade titanium for maximum strength and reliability. Additional orifice sizes and mount specifications available upon request.



RUBY & SAPPHIRE ORIFICES

DTI-05P

SIMILAR TO THE FOLLOWING
STANDARD
COMADUR TYPE 18

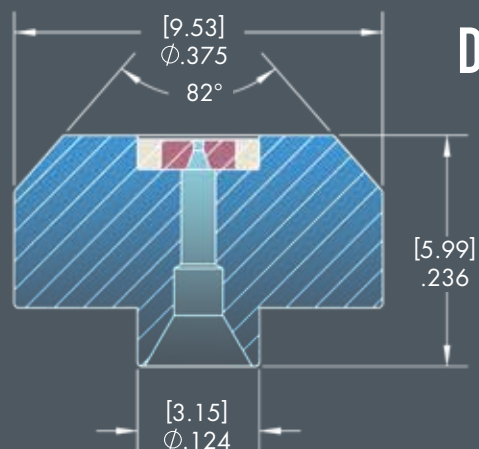

DTI-05P

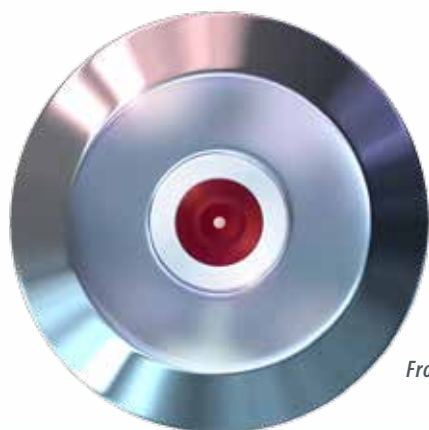

Front view

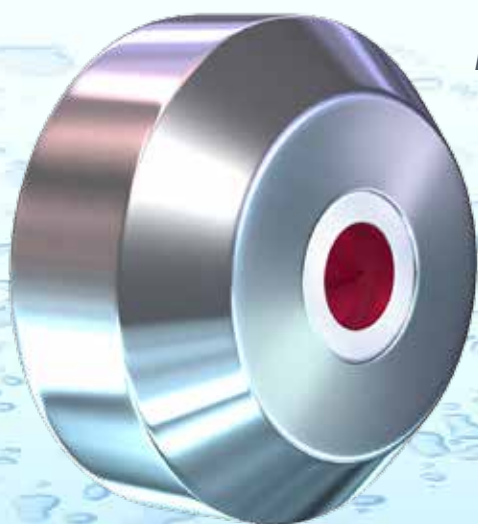

Enlarged view

PART NUMBERS & STANDARD SIZES

RUBY PLASTIC RETAINER	STANDARD SIZES		SAPPHIRE PLASTIC RETAINER
	inch	mm	

RA-05P-04	0.004	0,10	SA-05P-04
RA-05P-05	0.005	0,13	SA-05P-05
RA-05P-06	0.006	0,15	SA-05P-06
RA-05P-07	0.007	0,18	SA-05P-07
RA-05P-08	0.008	0,20	SA-05P-08
RA-05P-09	0.009	0,23	SA-05P-09
RA-05P-10	0.010	0,25	SA-05P-10
RA-05P-11	0.011	0,28	SA-05P-11
RA-05P-12	0.012	0,30	SA-05P-12
RA-05P-13	0.013	0,33	SA-05P-13
RA-05P-14	0.014	0,35	SA-05P-14
RA-05P-15	0.015	0,38	SA-05P-15
RA-05P-16	0.016	0,40	SA-05P-16
RA-05P-17	0.017	0,43	SA-05P-17
RA-05P-18	0.018	0,45	SA-05P-18



DIAMOND TECHNOLOGY INNOVATIONS

RUBY & SAPPHIRE ORIFICES

DTI-05B

SIMILAR TO THE FOLLOWING
STANDARD
COMADUR TYPE 18

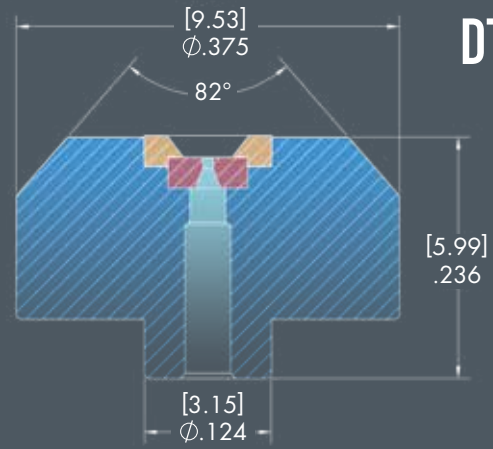

DTI-05B

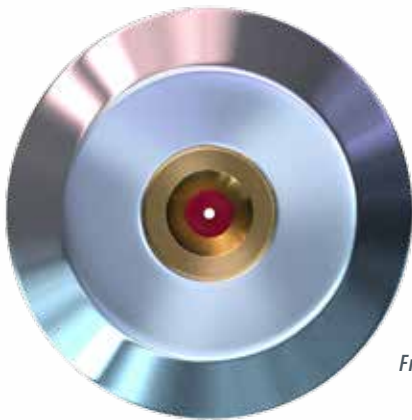

Front view

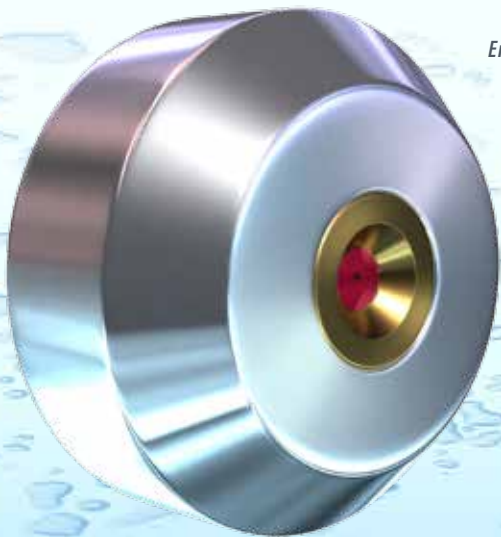

Enlarged view

PART NUMBERS & STANDARD SIZES

RUBY BRONZE RETAINER	STANDARD SIZES		SAPPHIRE BRONZE RETAINER
	inch	mm	

RA-05B-04	0.004	0,10	SA-05B-04
RA-05B-05	0.005	0,13	SA-05B-05
RA-05B-06	0.006	0,15	SA-05B-06
RA-05B-07	0.007	0,18	SA-05B-07
RA-05B-08	0.008	0,20	SA-05B-08
RA-05B-09	0.009	0,23	SA-05B-09
RA-05B-10	0.010	0,25	SA-05B-10
RA-05B-11	0.011	0,28	SA-05B-11
RA-05B-12	0.012	0,30	SA-05B-12
RA-05B-13	0.013	0,33	SA-05B-13
RA-05B-14	0.014	0,35	SA-05B-14
RA-05B-15	0.015	0,38	SA-05B-15
RA-05B-16	0.016	0,40	SA-05B-16
RA-05B-17	0.017	0,43	SA-05B-17
RA-05B-18	0.018	0,45	SA-05B-18



DIAMOND TECHNOLOGY INNOVATIONS

RUBY & SAPPHIRE ORIFICES

DTI-06P

SIMILAR TO THE FOLLOWING

PL-2

COMADUR TYPE 30

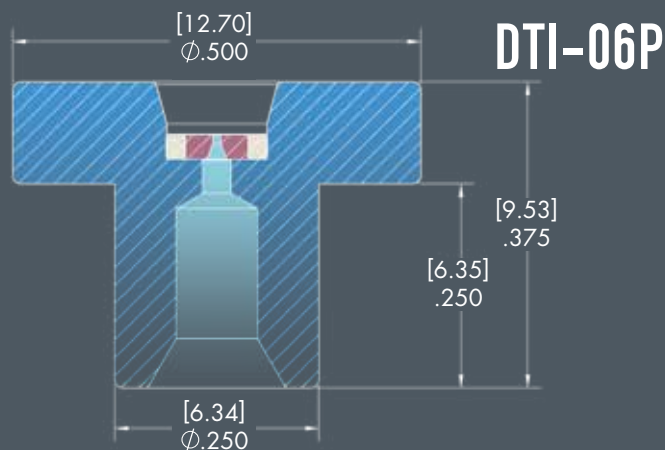

Front view

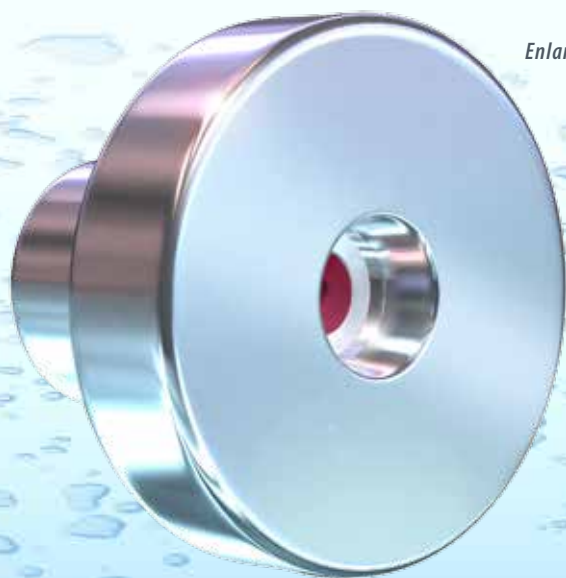

Enlarged view

PART NUMBERS & STANDARD SIZES

RUBY PLASTIC RETAINER	STANDARD SIZES		SAPPHIRE PLASTIC RETAINER
	inch	mm	

RA-06P-04	0.004	0,10	SA-06P-04
RA-06P-05	0.005	0,13	SA-06P-05
RA-06P-06	0.006	0,15	SA-06P-06
RA-06P-07	0.007	0,18	SA-06P-07
RA-06P-08	0.008	0,20	SA-06P-08
RA-06P-09	0.009	0,23	SA-06P-09
RA-06P-10	0.010	0,25	SA-06P-10
RA-06P-11	0.011	0,28	SA-06P-11
RA-06P-12	0.012	0,30	SA-06P-12
RA-06P-13	0.013	0,33	SA-06P-13
RA-06P-14	0.014	0,35	SA-06P-14
RA-06P-15	0.015	0,38	SA-06P-15
RA-06P-16	0.016	0,40	SA-06P-16
RA-06P-17	0.017	0,43	SA-06P-17
RA-06P-18	0.018	0,45	SA-06P-18



DIAMOND TECHNOLOGY INNOVATIONS

RUBY & SAPPHIRE ORIFICES

DTI-14P

SIMILAR TO THE FOLLOWING

P - V

COMADUR TYPE 26

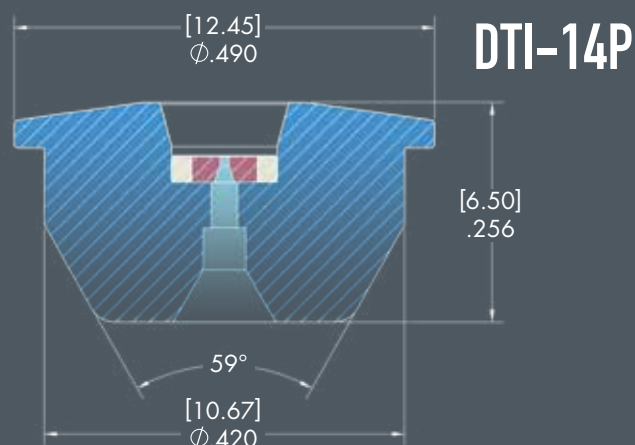

Front view

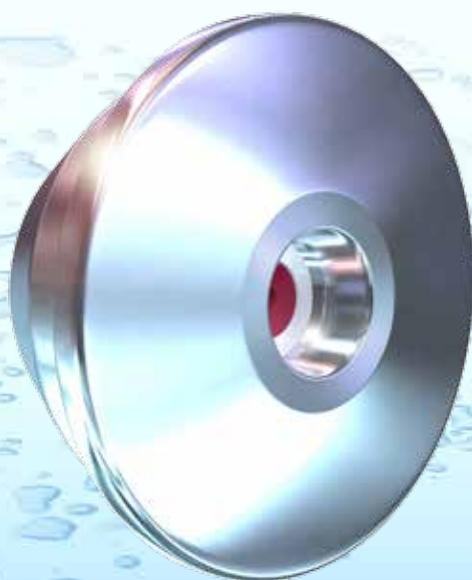

Enlarged view

PART NUMBERS & STANDARD SIZES

RUBY PLASTIC RETAINER	STANDARD SIZES		SAPPHIRE PLASTIC RETAINER
	inch	mm	

RA-14P-04	0.004	0,10	SA-14P-04
RA-14P-05	0.005	0,13	SA-14P-05
RA-14P-06	0.006	0,15	SA-14P-06
RA-14P-07	0.007	0,18	SA-14P-07
RA-14P-08	0.008	0,20	SA-14P-08
RA-14P-09	0.009	0,23	SA-14P-09
RA-14P-10	0.010	0,25	SA-14P-10
RA-14P-11	0.011	0,28	SA-14P-11
RA-14P-12	0.012	0,30	SA-14P-12
RA-14P-13	0.013	0,33	SA-14P-13
RA-14P-14	0.014	0,35	SA-14P-14
RA-14P-15	0.015	0,38	SA-14P-15
RA-14P-16	0.016	0,40	SA-14P-16
RA-14P-17	0.017	0,43	SA-14P-17
RA-14P-18	0.018	0,45	SA-14P-18



DIAMOND TECHNOLOGY INNOVATIONS

RUBY & SAPPHIRE ORIFICES

DTI-14B

SIMILAR TO THE FOLLOWING

P - V

COMADUR TYPE 26

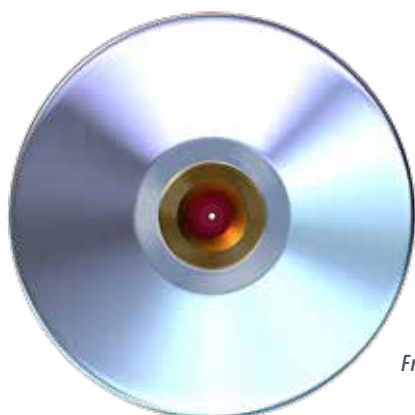
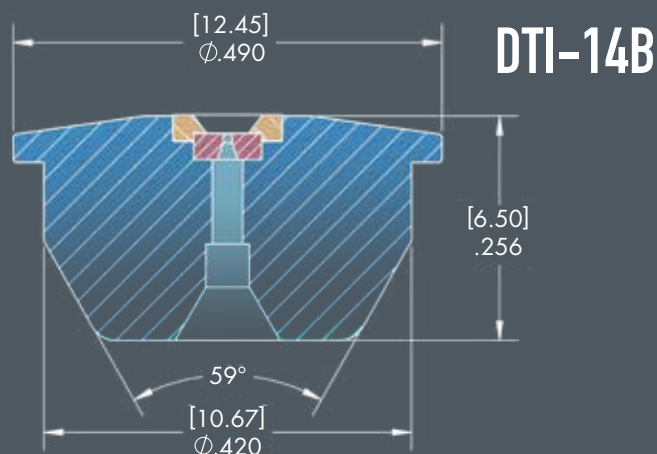

Front view

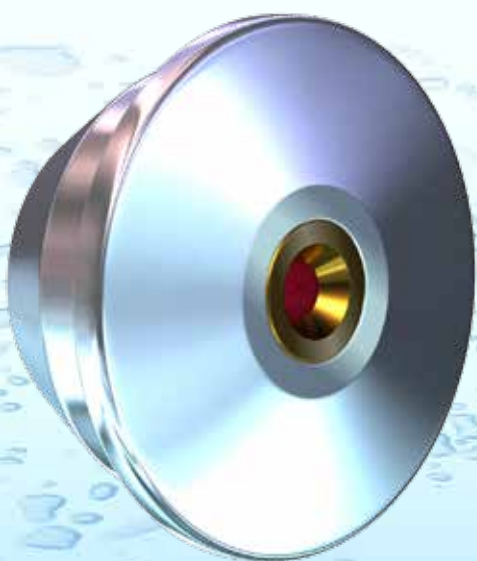

Enlarged view

PART NUMBERS & STANDARD SIZES

RUBY BRONZE RETAINER	STANDARD SIZES		SAPPHIRE BRONZE RETAINER
	inch	mm	
RA-14B-04	0.004	0,10	SA-14B-04
RA-14B-05	0.005	0,13	SA-14B-05
RA-14B-06	0.006	0,15	SA-14B-06
RA-14B-07	0.007	0,18	SA-14B-07
RA-14B-08	0.008	0,20	SA-14B-08
RA-14B-09	0.009	0,23	SA-14B-09
RA-14B-10	0.010	0,25	SA-14B-10
RA-14B-11	0.011	0,28	SA-14B-11
RA-14B-12	0.012	0,30	SA-14B-12
RA-14B-13	0.013	0,33	SA-14B-13
RA-14B-14	0.014	0,35	SA-14B-14
RA-14B-15	0.015	0,38	SA-14B-15
RA-14B-16	0.016	0,40	SA-14B-16
RA-14B-17	0.017	0,43	SA-14B-17
RA-14B-18	0.018	0,45	SA-14B-18



DIAMOND TECHNOLOGY INNOVATIONS

RUBY & SAPPHIRE ORIFICES

DTI-16P

SIMILAR TO THE FOLLOWING

P-III

COMADUR TYPE 23

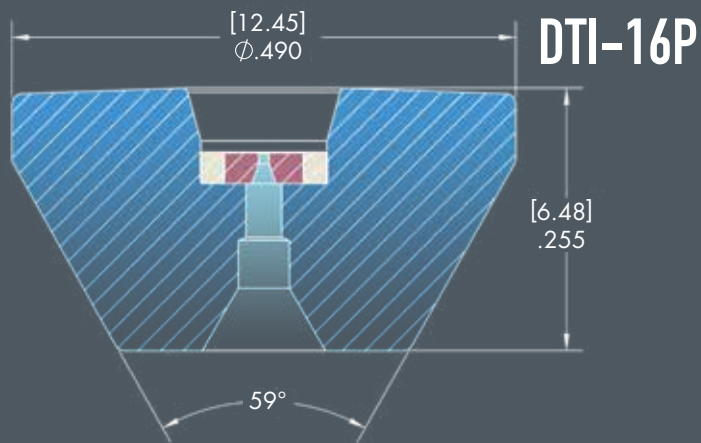

Front view

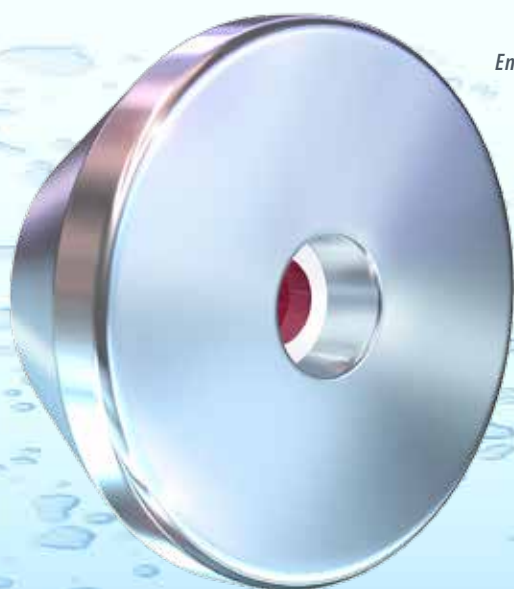

Enlarged view

PART NUMBERS & STANDARD SIZES

RUBY			SAPPHIRE
PLASTIC RETAINER	inch	mm	PLASTIC RETAINER

RA-16P-04	0.004	0,10	SA-16P-04
RA-16P-05	0.005	0,13	SA-16P-05
RA-16P-06	0.006	0,15	SA-16P-06
RA-16P-07	0.007	0,18	SA-16P-07
RA-16P-08	0.008	0,20	SA-16P-08
RA-16P-09	0.009	0,23	SA-16P-09
RA-16P-10	0.010	0,25	SA-16P-10
RA-16P-11	0.011	0,28	SA-16P-11
RA-16P-12	0.012	0,30	SA-16P-12
RA-16P-13	0.013	0,33	SA-16P-13
RA-16P-14	0.014	0,35	SA-16P-14
RA-16P-15	0.015	0,38	SA-16P-15
RA-16P-16	0.016	0,40	SA-16P-16
RA-16P-17	0.017	0,43	SA-16P-17
RA-16P-18	0.018	0,45	SA-16P-18



DIAMOND TECHNOLOGY INNOVATIONS

RUBY & SAPPHIRE ORIFICES

DTI-16B

SIMILAR TO THE FOLLOWING
P-III
COMADUR TYPE 23

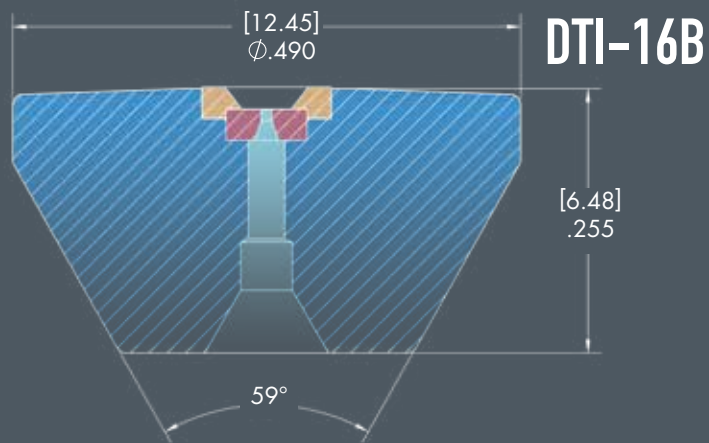

Front view

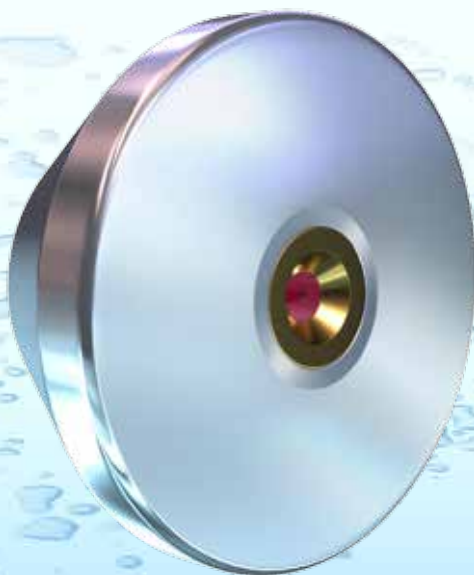

Enlarged view

PART NUMBERS & STANDARD SIZES

RUBY			SAPPHIRE
BRONZE RETAINER	inch	mm	BRONZE RETAINER

RA-16B-04	0.004	0,10	SA-16B-04
RA-16B-05	0.005	0,13	SA-16B-05
RA-16B-06	0.006	0,15	SA-16B-06
RA-16B-07	0.007	0,18	SA-16B-07
RA-16B-08	0.008	0,20	SA-16B-08
RA-16B-09	0.009	0,23	SA-16B-09
RA-16B-10	0.010	0,25	SA-16B-10
RA-16B-11	0.011	0,28	SA-16B-11
RA-16B-12	0.012	0,30	SA-16B-12
RA-16B-13	0.013	0,33	SA-16B-13
RA-16B-14	0.014	0,35	SA-16B-14
RA-16B-15	0.015	0,38	SA-16B-15
RA-16B-16	0.016	0,40	SA-16B-16
RA-16B-17	0.017	0,43	SA-16B-17
RA-16B-18	0.018	0,45	SA-16B-18



DIAMOND TECHNOLOGY INNOVATIONS

RUBY & SAPPHIRE ORIFICES

DTI-20P

SIMILAR TO THE FOLLOWING
P-IV

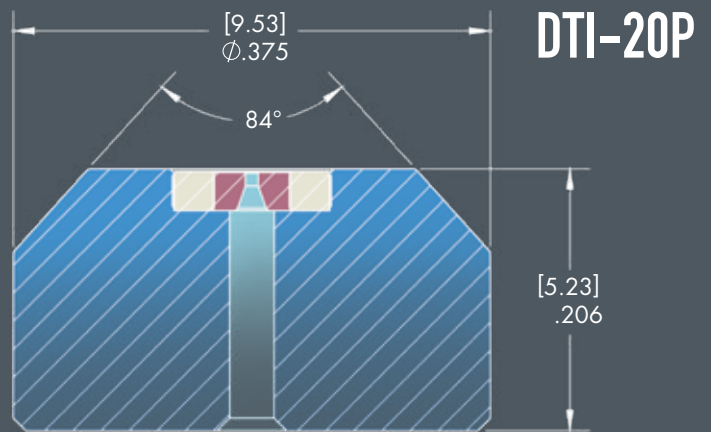

Front view

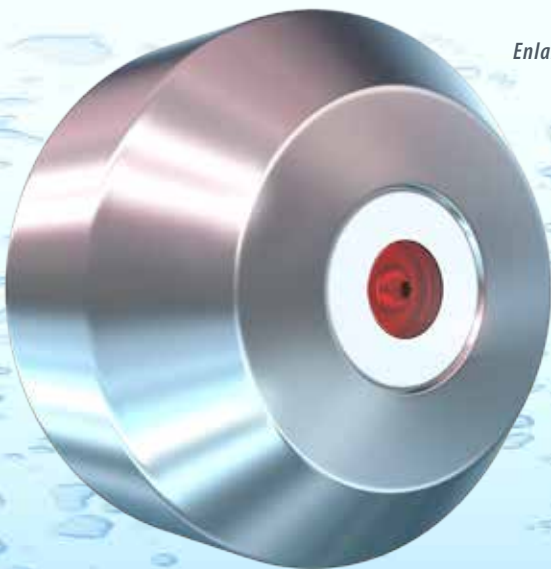

Enlarged view

PART NUMBERS & STANDARD SIZES

RUBY PLASTIC RETAINER	STANDARD SIZES		SAPPHIRE PLASTIC RETAINER
	inch	mm	

RA-20P-04	0.004	0,10	SA-20P-04
RA-20P-05	0.005	0,13	SA-20P-05
RA-20P-06	0.006	0,15	SA-20P-06
RA-20P-07	0.007	0,18	SA-20P-07
RA-20P-08	0.008	0,20	SA-20P-08
RA-20P-09	0.009	0,23	SA-20P-09
RA-20P-10	0.010	0,25	SA-20P-10
RA-20P-11	0.011	0,28	SA-20P-11
RA-20P-12	0.012	0,30	SA-20P-12
RA-20P-13	0.013	0,33	SA-20P-13
RA-20P-14	0.014	0,35	SA-20P-14
RA-20P-15	0.015	0,38	SA-20P-15
RA-20P-16	0.016	0,40	SA-20P-16
RA-20P-17	0.017	0,43	SA-20P-17
RA-20P-18	0.018	0,45	SA-20P-18



DIAMOND TECHNOLOGY INNOVATIONS

RUBY & SAPPHIRE ORIFICES

DTI-28P

SIMILAR TO THE FOLLOWING
COMADUR TYPE 27

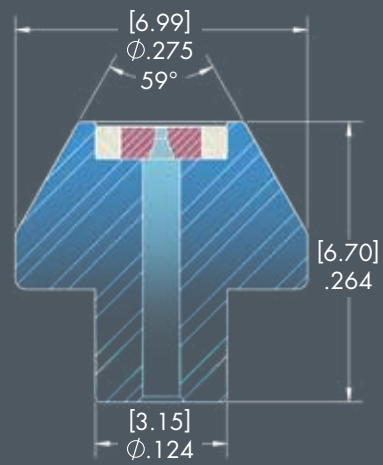

DTI-28P



Front view

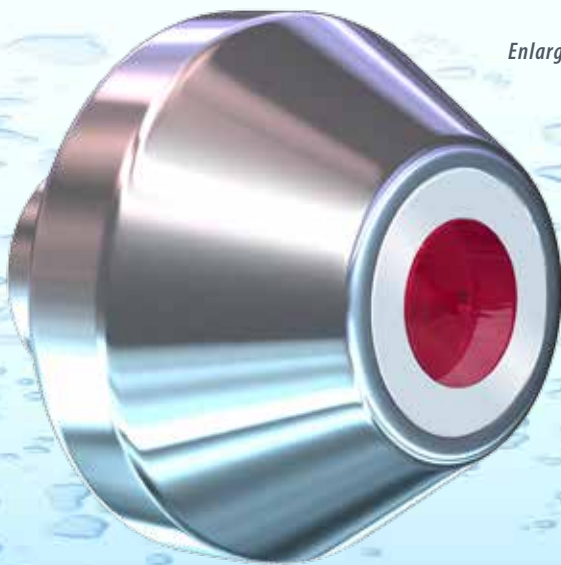

Enlarged view

PART NUMBERS & STANDARD SIZES

RUBY PLASTIC RETAINER	STANDARD SIZES		SAPPHIRE PLASTIC RETAINER
	inch	mm	
RA-28P-04	0.004	0,10	SA-28P-04
RA-28P-05	0.005	0,13	SA-28P-05
RA-28P-06	0.006	0,15	SA-28P-06
RA-28P-07	0.007	0,18	SA-28P-07
RA-28P-08	0.008	0,20	SA-28P-08
RA-28P-09	0.009	0,23	SA-28P-09
RA-28P-10	0.010	0,25	SA-28P-10
RA-28P-11	0.011	0,28	SA-28P-11
RA-28P-12	0.012	0,30	SA-28P-12
RA-28P-13	0.013	0,33	SA-28P-13
RA-28P-14	0.014	0,35	SA-28P-14
RA-28P-15	0.015	0,38	SA-28P-15
RA-28P-16	0.016	0,40	SA-28P-16
RA-28P-17	0.017	0,43	SA-28P-17
RA-28P-18	0.018	0,45	SA-28P-18



DIAMOND TECHNOLOGY INNOVATIONS

RUBY & SAPPHIRE ORIFICES

DTI-28B

SIMILAR TO THE FOLLOWING
COMADUR TYPE 27

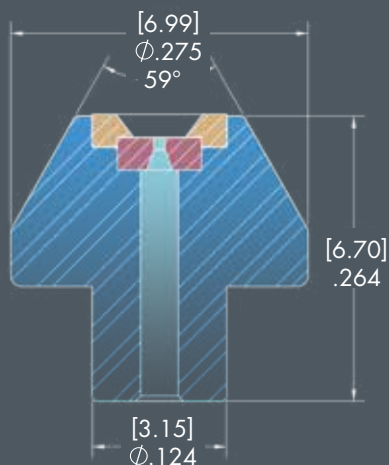

DTI-28B

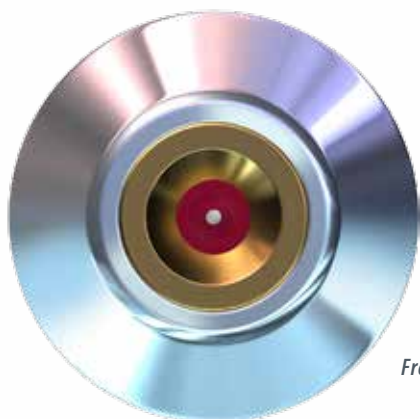

Front view

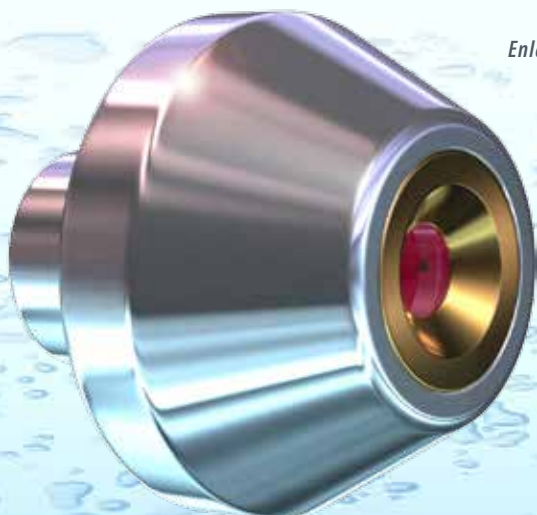

Enlarged view

PART NUMBERS & STANDARD SIZES

RUBY BRONZE RETAINER	STANDARD SIZES		SAPPHIRE BRONZE RETAINER
	inch	mm	

RA-28B-04	0.004	0,10	SA-28B-04
RA-28B-05	0.005	0,13	SA-28B-05
RA-28B-06	0.006	0,15	SA-28B-06
RA-28B-07	0.007	0,18	SA-28B-07
RA-28B-08	0.008	0,20	SA-28B-08
RA-28B-09	0.009	0,23	SA-28B-09
RA-28B-10	0.010	0,25	SA-28B-10
RA-28B-11	0.011	0,28	SA-28B-11
RA-28B-12	0.012	0,30	SA-28B-12
RA-28B-13	0.013	0,33	SA-28B-13
RA-28B-14	0.014	0,35	SA-28B-14
RA-28B-15	0.015	0,38	SA-28B-15
RA-28B-16	0.016	0,40	SA-28B-16
RA-28B-17	0.017	0,43	SA-28B-17
RA-28B-18	0.018	0,45	SA-28B-18



DIAMOND TECHNOLOGY INNOVATIONS

RUBY & SAPPHIRE ORIFICES

DTI-30P

SIMILAR TO THE FOLLOWING
COMADUR TYPE 25

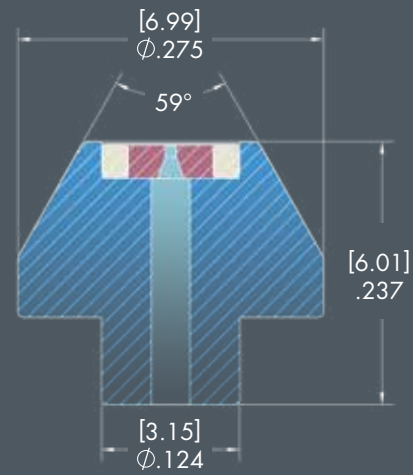

DTI-30P



Front view

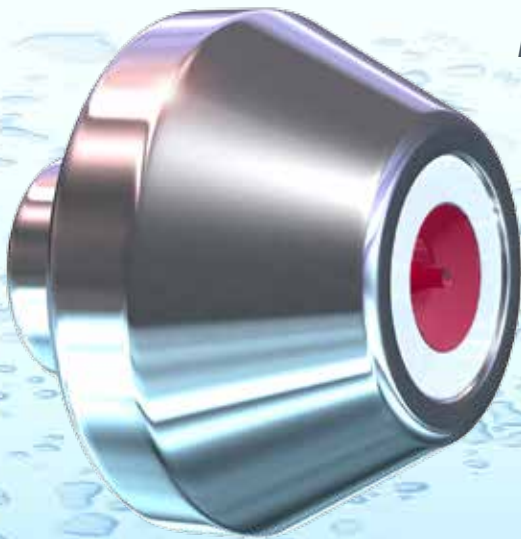

Enlarged view

PART NUMBERS & STANDARD SIZES

RUBY PLASTIC RETAINER	STANDARD SIZES		SAPPHIRE PLASTIC RETAINER
	inch	mm	

RA-30P-04	0.004	0,10	SA-30P-04
RA-30P-05	0.005	0,13	SA-30P-05
RA-30P-06	0.006	0,15	SA-30P-06
RA-30P-07	0.007	0,18	SA-30P-07
RA-30P-08	0.008	0,20	SA-30P-08
RA-30P-09	0.009	0,23	SA-30P-09
RA-30P-10	0.010	0,25	SA-30P-10
RA-30P-11	0.011	0,28	SA-30P-11
RA-30P-12	0.012	0,30	SA-30P-12
RA-30P-13	0.013	0,33	SA-30P-13
RA-30P-14	0.014	0,35	SA-30P-14
RA-30P-15	0.015	0,38	SA-30P-15
RA-30P-16	0.016	0,40	SA-30P-16
RA-30P-17	0.017	0,43	SA-30P-17
RA-30P-18	0.018	0,45	SA-30P-18



DIAMOND TECHNOLOGY INNOVATIONS

RUBY & SAPPHIRE ORIFICES

DTI-58P

SIMILAR TO THE FOLLOWING
LONG STEM
COMADUR TYPE 10

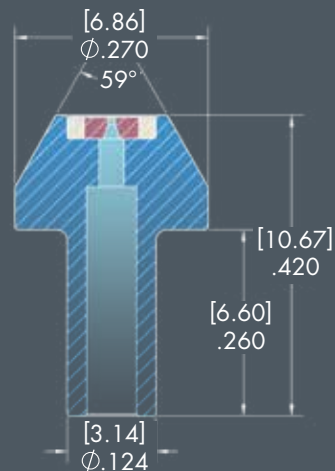

DTI-58P

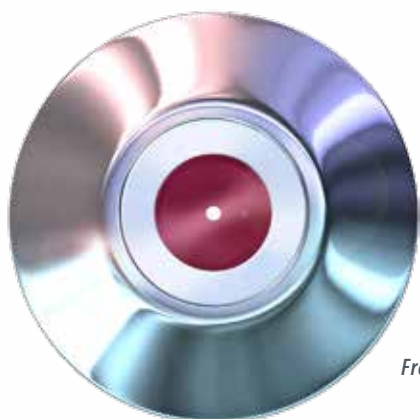

Front view



Enlarged view

PART NUMBERS & STANDARD SIZES

RUBY PLASTIC RETAINER	STANDARD SIZES		SAPPHIRE PLASTIC RETAINER
	inch	mm	

RA-58P-04	0.004	0,10	SA-58P-04
RA-58P-05	0.005	0,13	SA-58P-05
RA-58P-06	0.006	0,15	SA-58P-06
RA-58P-07	0.007	0,18	SA-58P-07
RA-58P-08	0.008	0,20	SA-58P-08
RA-58P-09	0.009	0,23	SA-58P-09
RA-58P-10	0.010	0,25	SA-58P-10
RA-58P-11	0.011	0,28	SA-58P-11
RA-58P-12	0.012	0,30	SA-58P-12
RA-58P-13	0.013	0,33	SA-58P-13
RA-58P-14	0.014	0,35	SA-58P-14
RA-58P-15	0.015	0,38	SA-58P-15
RA-58P-16	0.016	0,40	SA-58P-16
RA-58P-17	0.017	0,43	SA-58P-17
RA-58P-18	0.018	0,45	SA-58P-18



DIAMOND TECHNOLOGY INNOVATIONS

RUBY & SAPPHIRE ORIFICES

DTI-58B

SIMILAR TO THE FOLLOWING
LONG STEM
COMADUR TYPE 10

DTI-58B

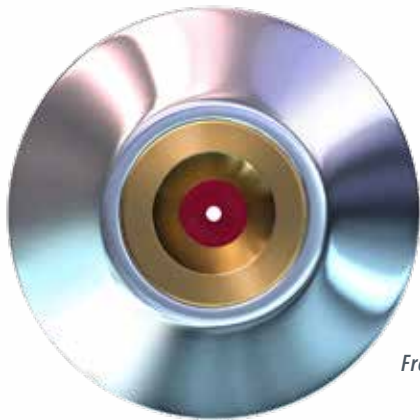
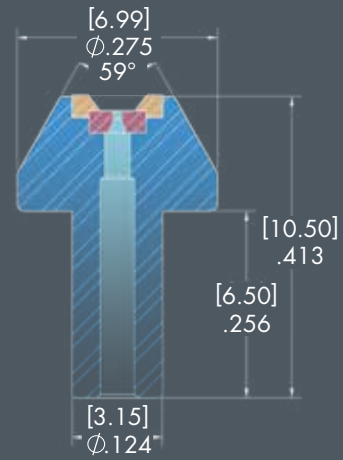

Front view

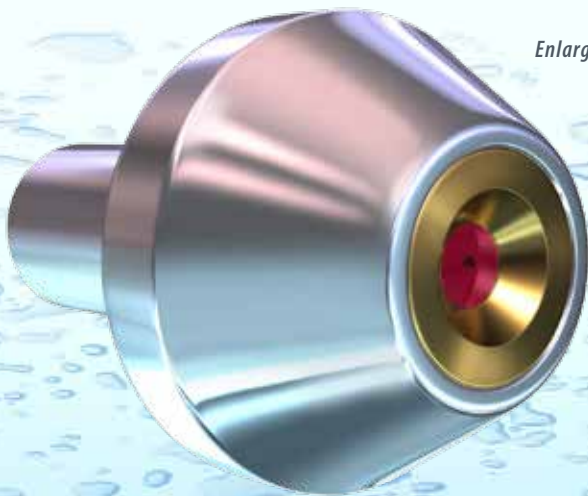

Enlarged view

PART NUMBERS & STANDARD SIZES

RUBY BRONZE RETAINER	STANDARD SIZES		SAPPHIRE BRONZE RETAINER
	inch	mm	
RA-58B-04	0.004	0,10	SA-58B-04
RA-58B-05	0.005	0,13	SA-58B-05
RA-58B-06	0.006	0,15	SA-58B-06
RA-58B-07	0.007	0,18	SA-58B-07
RA-58B-08	0.008	0,20	SA-58B-08
RA-58B-09	0.009	0,23	SA-58B-09
RA-58B-10	0.010	0,25	SA-58B-10
RA-58B-11	0.011	0,28	SA-58B-11
RA-58B-12	0.012	0,30	SA-58B-12
RA-58B-13	0.013	0,33	SA-58B-13
RA-58B-14	0.014	0,35	SA-58B-14
RA-58B-15	0.015	0,38	SA-58B-15
RA-58B-16	0.016	0,40	SA-58B-16
RA-58B-17	0.017	0,43	SA-58B-17
RA-58B-18	0.018	0,45	SA-58B-18



DIAMOND TECHNOLOGY INNOVATIONS

RUBY & SAPPHIRE ORIFICES

DTI-62P

SIMILAR TO THE FOLLOWING
P-II STEP
COMADUR TYPE 14

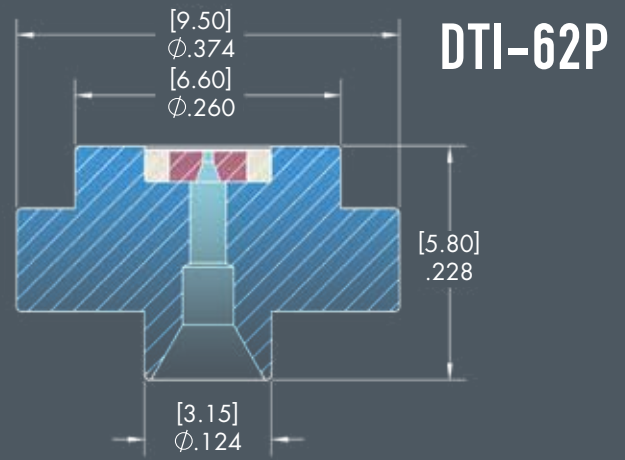

Front view



Enlarged view

PART NUMBERS & STANDARD SIZES

RUBY			SAPPHIRE
PLASTIC RETAINER	inch	mm	PLASTIC RETAINER

RA-62P-04	0.004	0,10	SA-62P-04
RA-62P-05	0.005	0,13	SA-62P-05
RA-62P-06	0.006	0,15	SA-62P-06
RA-62P-07	0.007	0,18	SA-62P-07
RA-62P-08	0.008	0,20	SA-62P-08
RA-62P-09	0.009	0,23	SA-62P-09
RA-62P-10	0.010	0,25	SA-62P-10
RA-62P-11	0.011	0,28	SA-62P-11
RA-62P-12	0.012	0,30	SA-62P-12
RA-62P-13	0.013	0,33	SA-62P-13
RA-62P-14	0.014	0,35	SA-62P-14
RA-62P-15	0.015	0,38	SA-62P-15
RA-62P-16	0.016	0,40	SA-62P-16
RA-62P-17	0.017	0,43	SA-62P-17
RA-62P-18	0.018	0,45	SA-62P-18



DIAMOND TECHNOLOGY INNOVATIONS

RUBY & SAPPHIRE ORIFICES

DTI-65P

SIMILAR TO THE FOLLOWING
LOW MASS
COMADURE TYPE 20



Front view

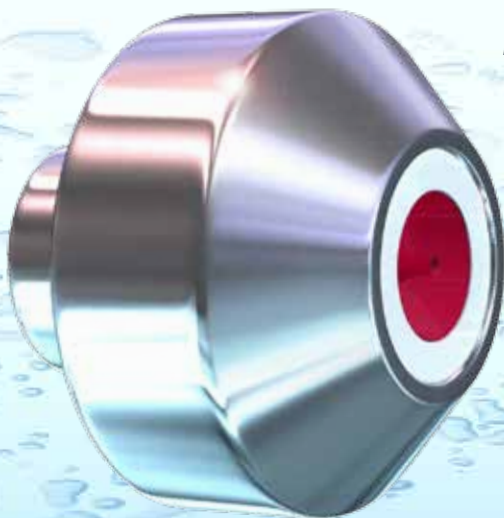

Enlarged view

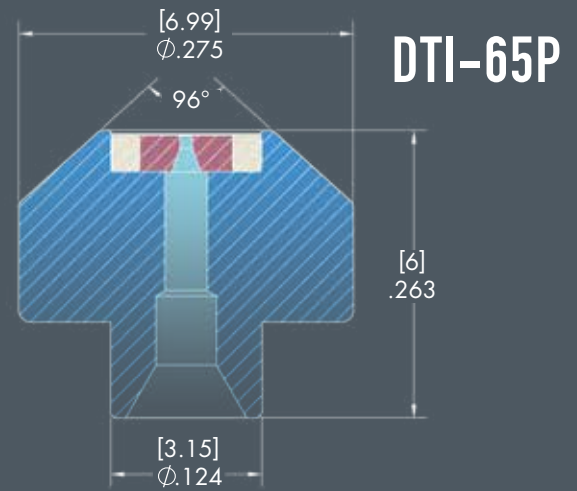

PART NUMBERS & STANDARD SIZES

RUBY PLASTIC RETAINER	STANDARD SIZES		SAPPHIRE PLASTIC RETAINER
	inch	mm	
RA-65P-04	0.004	0,10	SA-65P-04
RA-65P-05	0.005	0,13	SA-65P-05
RA-65P-06	0.006	0,15	SA-65P-06
RA-65P-07	0.007	0,18	SA-65P-07
RA-65P-08	0.008	0,20	SA-65P-08
RA-65P-09	0.009	0,23	SA-65P-09
RA-65P-10	0.010	0,25	SA-65P-10
RA-65P-11	0.011	0,28	SA-65P-11
RA-65P-12	0.012	0,30	SA-65P-12
RA-65P-13	0.013	0,33	SA-65P-13
RA-65P-14	0.014	0,35	SA-65P-14
RA-65P-15	0.015	0,38	SA-65P-15
RA-65P-16	0.016	0,40	SA-65P-16
RA-65P-17	0.017	0,43	SA-65P-17
RA-65P-18	0.018	0,45	SA-65P-18



DIAMOND TECHNOLOGY INNOVATIONS

SLIM LINE INTEGRAL CARTRIDGE EDUCTOR

slice²

- ◆ 360° abrasive inlet rotation
- ◆ MAXIMIZED wear life
- ◆ GREATER cutting speeds
- ◆ PRECISION multi-axis cutting
- ◆ SUPERIOR edge quality
- ◆ OPTIMIZED jet stream alignment
- ◆ dti CORE™ Diamond inside
- ◆ INCREASED adaptability

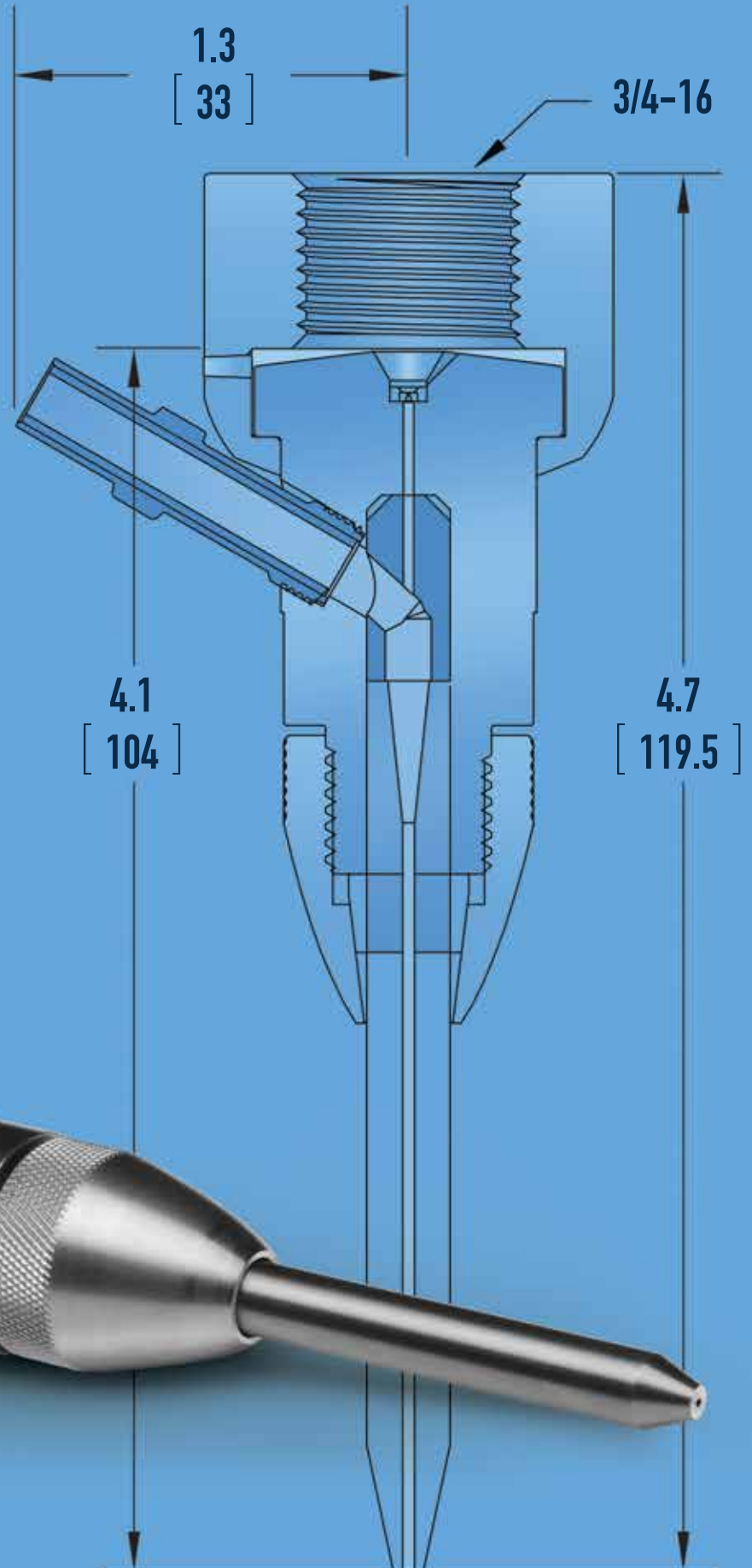

dti
CORE.

DIAMOND TECHNOLOGY INNOVATIONS

SLICE2 ACCESSORIES

ADDED VERSATILITY

With the newly enhanced SLICE2, it is now possible to order the cutting head configurations and accessories perfect for your operation. SLICE2's ability to adapt to an even wider range of waterjet systems worldwide allows for greater versatility in ordering and ensures the cutting head will meet your specific needs.



DA-ABR-01
Abrasive Inlet



D-NUT-18
Mixing Tube Clamp Nut



D-COL-11
Collet

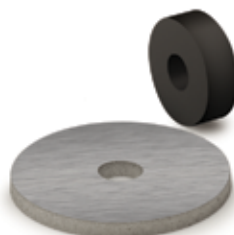

DA-GRD-01
Splash Guard



MA-FIL-03
Diamond Guard Assembly

M-FIL-01
Diamond Guard Filter

M-ADP-06
Diamond Guard Adapter

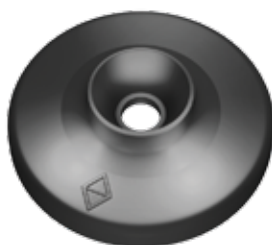

D-GRD-02
Splash Guard 2

For More Diamond Guard Filter options see page 12.

CHOOSE YOUR SLICE2

CUSTOMIZE YOUR ORDER

Insert your thread style and size

SLC2- X - XX

SLC2- X - XX-R5

With Roctec® 500 Mixing Chamber

■ R (Right) or L (Left)

■ Orifice Size

- ◆ Standard orifice size range: 0.008" - 0.018"
- ◆ Fits with standard .281" or 7.14mm nozzle (nozzle not included)

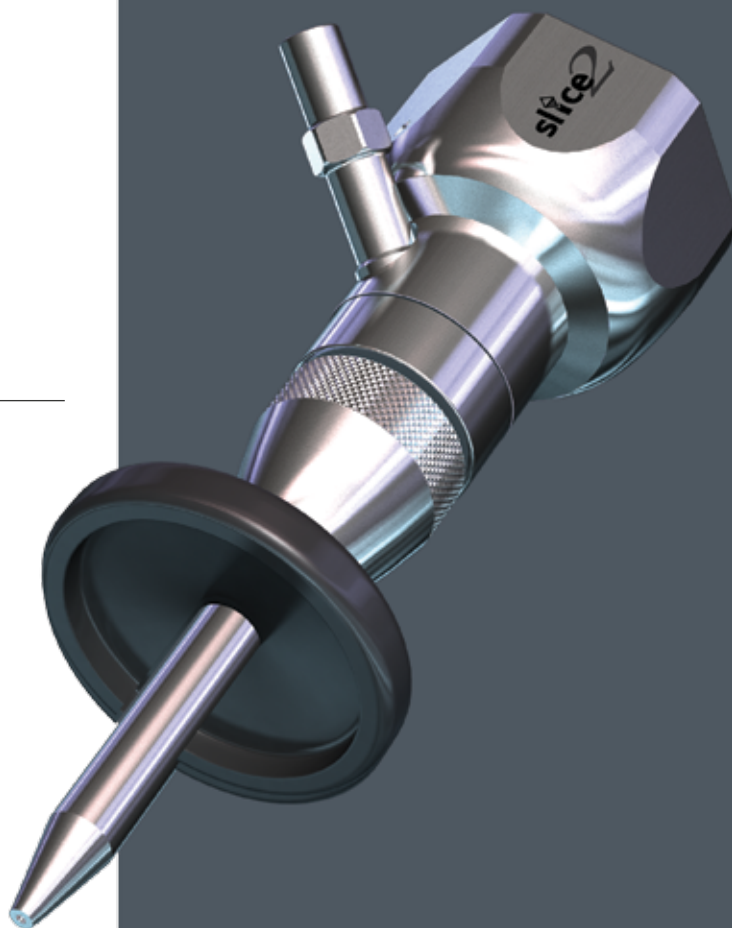



dti™ is a manufacturer of orifices and cutting heads for OEMs and distributors only. To place an order, contact your waterjet supplier or contact us for your nearest authorized dealer.

DIAMOND TECHNOLOGY INNOVATIONS

1043-A Kaiser Rd SW
Olympia, WA 98512

Phone 855.866.1337
www.dtiINSIDE.com
www.dtiEXACT.com



THE POWER TO PRODUCE MORE